

INSTALLER AND OWNER GUIDE

Model 940 Heat Engine

INSET LIVE FUEL EFFECT GAS FIRE

INCORPORATING THE **FireSlide**[®] CONTROL

This heat engine is designed for use with approved cast fascias and spacer frame / fret combinations.

(GC No. 32-032-71)



For further advice please contact the retailer or company from where you purchased your fire

INSTALLER: Please leave this guide with the owner

THIS APPLIANCE IS FOR USE WITH NATURAL GAS (G20).

**WHEN CONVERTED USING CONVERSION KIT NO. 0595211 THIS APPLIANCE
IS FOR USE WITH PROPANE GAS (G31).**

**THIS APPLIANCE IS SUITABLE ONLY FOR INSTALLATION IN THE UNITED
KINGDOM (GB) AND THE REPUBLIC OF IRELAND (IE).**

© Baxi Heating U.K. Limited 2010.

All rights reserved. No part of this publication may be reproduced in any material form (including photocopying), stored in any medium by electronic means (including in any retrieval system or database) or transmitted, in any form or by any means, whether electronic, mechanical, recording or otherwise, without the prior written permission of the copyright owner.

Applications for the copyright owner's permission to reproduce any part of this publication should be made, giving details of the proposed use, to the following address: The Company Secretary, Baxi Heating UK Limited, The Wyvern Business Park, Stanier Way, Derby, DE21 6BF.

Warning: Any person who does any unauthorised act in relation to a copyright work may be liable to criminal prosecution and civil claims for damages.

Valor Fires, Erdington, Birmingham B24 9QP
www.firesandstoves.co.uk

Because our policy is one of constant development and improvement, details may vary slightly from those given in this publication.

Safety First.

This gas fire is CE Approved and designed to meet the appropriate British Standards and Safety Marks.



Quality and Excellence.

This fire has been manufactured to the highest standards of quality and excellence and was manufactured under a BS EN ISO 9001 quality system accepted by the British Standards Institute.



The Highest Standards

The manufacturer is a member of SBGI and HHIC (Heating and Hot water Industry Council) which works to ensure high standards of safety, quality and performance.



Careful Installation

This gas fire must be installed by a competent GAS SAFE REGISTER engineer (GAS SAFE REGISTER or CORGI engineer outside of UK) in accordance with our installer guide and should not be fitted directly on to a carpet or floor of combustible material.



INSTALLER GUIDE

FOR OWNER GUIDE SEE PAGES 38 TO 46

INSTALLER GUIDE

CONTENTS

<u>Section</u>	<u>Heading</u>	<u>Page</u>
	INSTALLER GUIDE	4 - 37
	OWNER GUIDE	38 - 46
1.	SAFETY AND UNPACKING	7
2.	APPLIANCE DATA AND EFFICIENCY	8
	2.1 General information.	8
	2.2 Efficiency.	8
3.	GENERAL INSTALLATION REQUIREMENTS	9
	3.1 Regulations, Standards and Law.	9
	3.2 Ventilation requirements.	10
	3.3 The Atmosphere sensing device (ASD).	10
	3.4 Fireguard requirements.	10
	3.5 Room considerations.	10
	3.6 Chimney preparation.	10
	3.7 Fireplace preparation.	11
	3.8 The hearth.	11
	3.9 Fireplace clearances.	12
	3.10 Installation options.	12
	3.10.1 Conventional fireplace and hearth.	12
	3.10.1.1 'Hole-in-the-wall' Installations	13
	3.10.2 Metal flue box and hearth.	14
	3.10.3 Precast concrete or clay flue block system and hearth.	15
	3.11 Flues.	15
	3.12 Propane fires.	16
4.	PACK CONTENTS	16
5.	FIREPLACE CHECK	18
6.	IGNITION CHECK	19
7.	GAS SUPPLY CONNECTION	19
8.	PREPARING APPLIANCE FOR INSTALLATION	20
9.	CONVECTION BOX INSTALLATION	22
	9.1 Method 1 - Front fixing to fireplace surround.	22
	9.2 Method 2 - Cable retention and floor fixing.	22
	9.3 Sealing floor front - all installations.	24

Continued on next page

INSTALLER GUIDE

CONTENTS (Continued)

<u>Section</u>	<u>Heading</u>	<u>Page</u>
10.	BURNER & SUPPLY PIPE INSTALLATION	25
10.1	Burner and supply pipe installation.	25
10.2	Preliminary burner checks.	25
10.3	Inlet pressure check.	26
11.	CERAMIC WALLS INSTALLATION	26
12.	FITTING THE CERAMIC FUEL EFFECT	27
13.	FITTING THE FASCIA	28
14.	FULL OPERATING CHECKS	28
14.1	Check the control settings.	28
14.2	Check for spillage.	29
14.3	Flame supervision and spillage monitoring system.	29
15.	FINAL REVIEW	30
16.	SERVICING & PARTS REPLACEMENT	31
16.1	Checking the aeration setting of the burner.	32
16.2	To remove the ignition microswitch.	32
16.3	To remove the gas shut-off microswitch.	32
16.4	To remove the fascia.	33
16.5	To replace the control slide unit.	33
16.6	To replace the control slide button.	33
16.7	To remove the burner unit.	33
16.8	To remove the electronic ignition generator.	34
16.9	To remove the thermocouple interrupter block.	34
16.10	To remove the pilot unit.	35
16.11	To remove the shut-off tap.	35
16.12	To remove the gas flow rate controller.	36
16.13	To replace the burner.	36
16.14	To remove the main burner injector.	37
16.15	To remove the appliance from the fireplace.	37

INSTALLER GUIDE

1. SAFETY AND UNPACKING

Installer

Before continuing any further with the installation of this appliance please read the following guide to manual handling.

- The lifting weight of the heat engine and convection box is 11.5kg.
- One person should be sufficient to lift the heat engine and convection box. If for any reason this weight is considered too heavy then obtain assistance.
- When lifting always keep your back straight. Bend your legs and not your back.
- Avoid twisting at the waist. It is better to reposition your feet.
- Avoid upper body/top heavy bending. Do not lean forward or sideways whilst handling the heat engine.
- Always grip with the palm of the hand. Do not use the tips of fingers for support.
- Always keep the heat engine and convection box as close to the body as possible. This will minimise the cantilever action.
- Use gloves to provide additional grip.
- Always use assistance if required.

This product uses fuel effect pieces and burner compartment walls containing Refractory Ceramic Fibres (RCF), which are man-made vitreous silicate fibres. Excessive exposure to these materials may cause irritation to eyes, skin and respiratory tract. Consequently, it is important to take care when handling these articles to ensure that the release of dust is kept to a minimum. To ensure that the release of fibres from these RCF articles is kept to a minimum, during installation and servicing we recommend that you use a HEPA filtered vacuum to remove any dust and soot accumulated in and around the fire before and after working on the fire. When replacing these articles we recommend that the replaced items are not broken up, but are sealed within a heavy duty polythene bag, clearly labelled as RCF waste. RCF waste is classed as a stable, non-reactive hazardous waste and may be disposed at a landfill licenced to accept such waste. Protective clothing is not required when handling these articles, but we recommend the use of suitable gloves to prevent irritation. We also recommend you follow the normal hygiene rules of not smoking, eating or drinking in the work area and always wash your hands before eating or drinking.

This appliance does not contain any component manufactured from asbestos or asbestos related products.

INSTALLER GUIDE

2. APPLIANCE DATA AND EFFICIENCY

2.1 General information.

Gas	Natural (G20)	Propane (G31) *
Inlet Pressure	20mbar	37mbar
Input - Max. (Gross)	6.85kW (23,400 Btu/h)	6.7kW (22,860 Btu/h)
Input - Min. (Gross)	2.7kW (9,410 Btu/h)	4.3kW (14,670 Btu/h)
Inlet Test Pressure (Cold)	20.0 ± 1.0mbar (8.0 ± 0.4in w.g.)	37.0 ± 1.0 mbar (14.85 ± 0.4in w.g.)
Gas Connection	8mm pipe	8mm pipe
Burner Injector	Cat 82 - 074	Size 132
Pilot & Atmosphere Sensing Device	Copreci Ref. O.D.S 21500/166	Copreci Ref. O.D.S 21500/166 Fitted with RBM 180 -02 injector
Ignition	Electronic (Battery 9V PP3)	Electronic (Battery 9V PP3)
Aeration	Factory set	Non-adjustable

*When converted using kit 0595211.

The appliance information label is located on a plate at the base of the fire.

2.2 Efficiency.

The efficiency of this appliance has been measured as specified in BS 7977 - 1 and the result is as below:

<u>Model</u>	<u>Efficiency % (Gross)</u>
940	58
940 when converted to LPG.	61

The gross calorific value of the fuel has been used for this efficiency calculation. The test data from which it has been calculated has been certified by Advantica Certification services (0087). The efficiency value may be used in the UK Government's Standard Assessment Procedure (SAP) for energy rating of dwellings.

The conversion of **net** efficiency to **gross** was achieved by multiplying the net efficiency by the following conversion factor from Table E3 of SAP 2005, rounding down to the nearest whole number.

INSTALLER GUIDE

Gas	Conversion factor from net to gross efficiency
Natural Gas	0.901
LPG	0.921

3. GENERAL INSTALLATION REQUIREMENTS

3.1 Regulations, Standards and Law.

The installation must be in accordance with these instructions.

For the user's protection, in the United Kingdom it is the law that all gas appliances are installed by competent persons in accordance with the current edition of the Gas Safety (Installation and Use) Regulations. Failure to install the appliance correctly could lead to prosecution. GAS SAFE REGISTER and CORGI require their members to work to recognised standards.

In the United Kingdom the installation must also be in accordance with:

All the relevant parts of local regulations.

All relevant codes of practice.

The relevant parts of the current editions of the following British Standards:-

BS EN 1856 Part 1 - Chimneys - Requirements for metal chimneys.

BS 715 - Specification for metal flue boxes for gas-fired appliances not exceeding 20kW.

BS EN 1858 - Chimneys - Components - Concrete flue blocks.

BS EN 1806 - Chimneys - Clay / ceramic flue blocks.

BS EN 1856 Part 1 - Chimneys - Requirements for metal chimneys.

BS 5440 Part 1 - Installation of flues.

BS 5440 Part 2 - Installation and maintenance of flues and ventilation for gas appliances of rated input not exceeding 70 kW net (1st, 2nd and 3rd family gases).

BS 6461 Part 1 - Masonry chimney & flues - Installation

BS 1251 - Fireplace components

BS 5871 Part 2 - Installation - Inset LFE gas fires

BS 6891 - Gas pipework installation

- In England and Wales, the current edition of the Building Regulations issued by the Department of the Environment and the Welsh Office.
- In Scotland, the current edition of the Building Standards (Scotland) Regulations issued by the Scottish Executive.
- In Northern Ireland, the current edition of the Building regulations (Northern Ireland) issued by the Department of the Environment for Northern Ireland.
- In the republic of Ireland the installation must be carried out by a competent person and also conform to the relevant parts of:
 - a) The current edition of IS 813 "Domestic Gas Installations"
 - b) All relevant national and local rules in force.

INSTALLER GUIDE

Where no specific instructions are given, reference should be made to the relevant British Standard Code of Practice.

3.2 Ventilation requirements.

Normal adventitious ventilation is usually sufficient to satisfy the ventilation requirements of this appliance. In GB reference should be made to BS 5871 Part 2 and in IE reference should be made to the current edition of IS 813 “Domestic Gas Installations” which makes clear the conditions that must be met to demonstrate that sufficient ventilation is available.

3.3 The Atmosphere sensing device (ASD).

The appliance is fitted with an A.S.D (Atmosphere sensing device). If the appliance closes down after a period of operation for no apparent reason, the consumer should be informed to stop using the appliance until the installation and appliance have been thoroughly checked. The A.S.D will shut the appliance down if an unacceptable amount of harmful products of combustion accumulate. Under no circumstances should the A.S.D be altered or bypassed in any way. Only a genuine manufacturers replacement part should be fitted. The individual A.S.D components are not replaceable.

3.4 Fireguard requirements.

A fireguard complying with BS 8423 should be fitted for the protection of young children, the elderly, the infirm or pet animals.

3.5 Room considerations.

3.5.1 This appliance must not be installed in any room that contains a bath or shower or where steam is regularly present.

3.5.2 An extractor fan may only be used in the same room as this appliance, or in any area from which ventilation for the appliance is taken, if it does not affect the safe performance of the appliance. Note the spillage test requirements detailed further on in this manual. If the fan is likely to affect the appliance, the appliance must not be installed unless the fan is permanently disconnected.

3.5.3 Note that soft wall coverings (e.g. embossed vinyl, etc.) are easily affected by heat. They may scorch or become discoloured when close to a heating appliance. Please bear this in mind when installing.

3.6 Chimney preparation.

3.6.1 If the appliance is intended to be installed to a chimney that was previously used for solid fuel, the flue must be swept clean prior to installation. All flues should be inspected for soundness and freedom from blockages.

INSTALLER GUIDE

3.6.2 Any chimney damper or restrictor should be removed. If removal is not possible, they must be secured in the open position.

3.7 Fireplace preparation.

3.7.1 If the fireplace opening is an under floor draught type, it must be sealed to stop any draughts.

3.7.2 The front face of the fireplace should be reasonably flat over the area covered by the convection box top and side flange seals to ensure good sealing. These faces should be made good if necessary. The fireplace floor should be reasonably flat to ensure that a good seal with the convection box can be made.

3.7.3 If the appliance is to be fitted against a wall with combustible cladding, the cladding must be removed from the area covered by the fascia. The cladding must also not touch the fascia (See figure 1). We suggest that the actual fascia is used as a template to mark the area for combustible cladding removal and that this area is increased by at least 2mm all round.

3.7.4 If the fireplace opening is greater than the acceptable dimensions given in this guide, do not use the back of a fire surround or marble to reduce the opening. This may cause cracking of the surround back or marble.

3.8 The hearth.

The appliance must be mounted behind a non-combustible hearth unless the conditions of section 3.10.1.1 are met (N.B. conglomerate marble hearths are considered as non-combustible). The appliance can be fitted to a purpose made proprietary class "O"-150°C surround. The hearth material must be at least 12mm thick. The periphery of the hearth (or fender) should be at least 50mm above floor level to discourage the placing of carpets or rugs over it.

The surface of the hearth must be sufficiently flat to enable the bottom of the front surround and the bottom front cover to be aligned horizontally. Any excessive unevenness (uneven tiles, Cotswold stone, etc.) should be rectified.

The appliance must not stand on combustible materials or carpets.

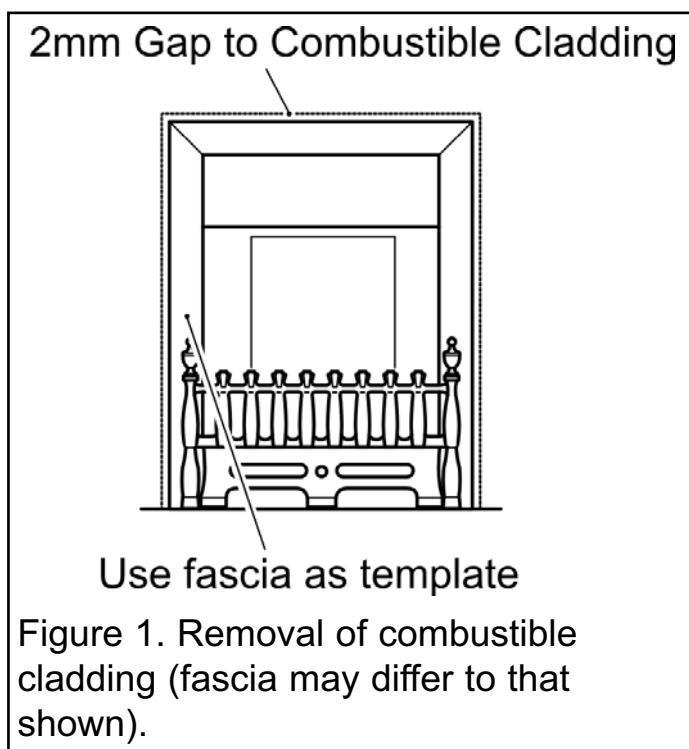

INSTALLER GUIDE

3.9 Fireplace clearances.

3.9.1 The minimum height from the top surface of the hearth to the underside of any shelf made from wood or other combustible materials is shown below: -

- For a shelf up to 150mm deep
Minimum height = 760mm.
- For a shelf deeper than 150mm
Minimum height = 760mm + 12.5mm for every 25mm depth over 150mm.
(See figure 2).

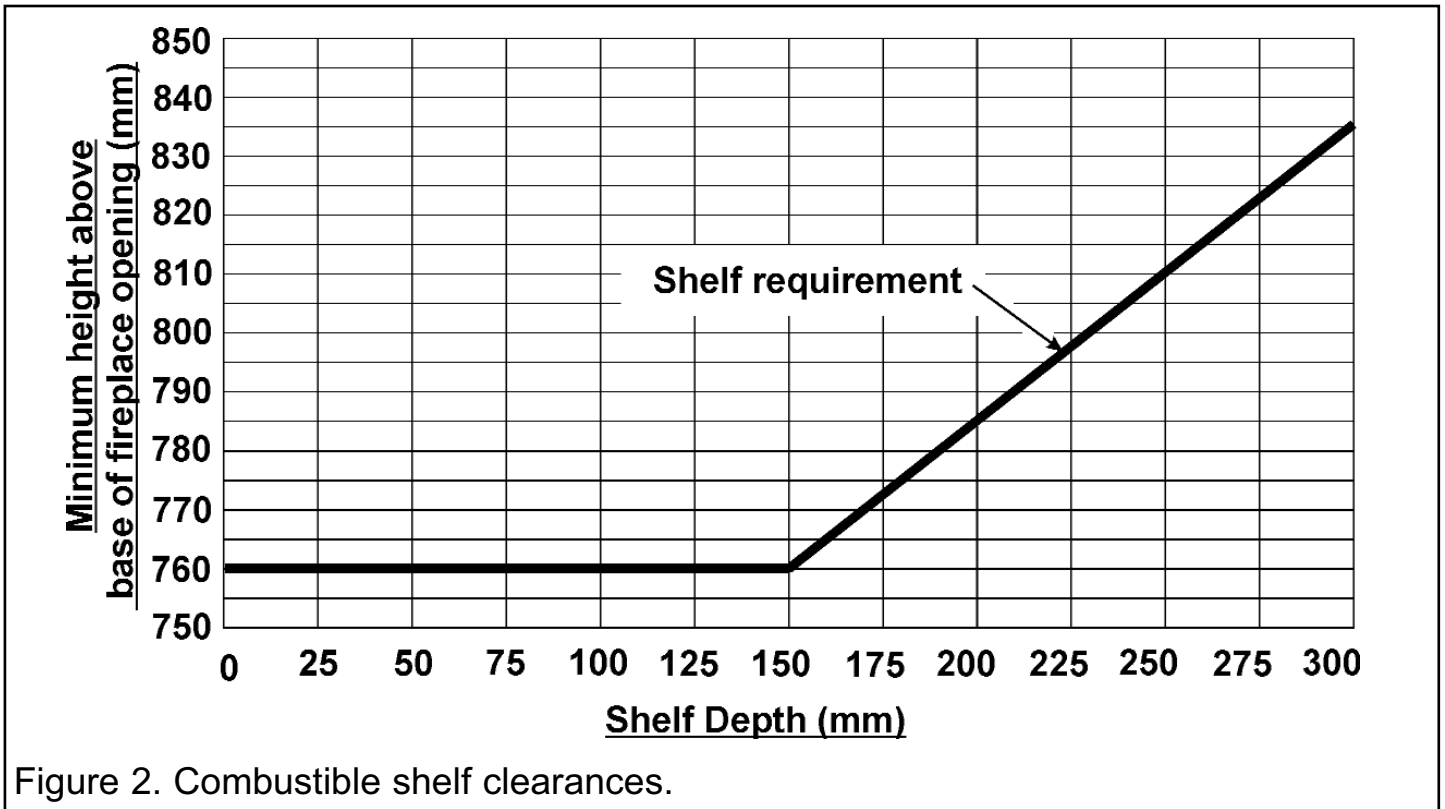

Figure 2. Combustible shelf clearances.

3.9.2 The minimum mandatory side clearance to combustible surfaces projecting beyond the front of the appliance is 100mm. For access purposes a 10mm clearance to non-combustible surfaces is recommended on the left side of the appliance, on the right side the recommended clearance is 50mm for access to the slider control.

3.10 Installation options.

In the United Kingdom, as supplied, the appliance can be installed in the following situations: -

3.10.1 Conventional fireplace and hearth.

To a fireplace complete with surround and hearth as shown in figure 3 and complying with BS1251 after removal of the fireback and sufficient material behind the fireback for a debris catchment space. The required fireplace and debris catchment area are shown in figure 4.

INSTALLER GUIDE

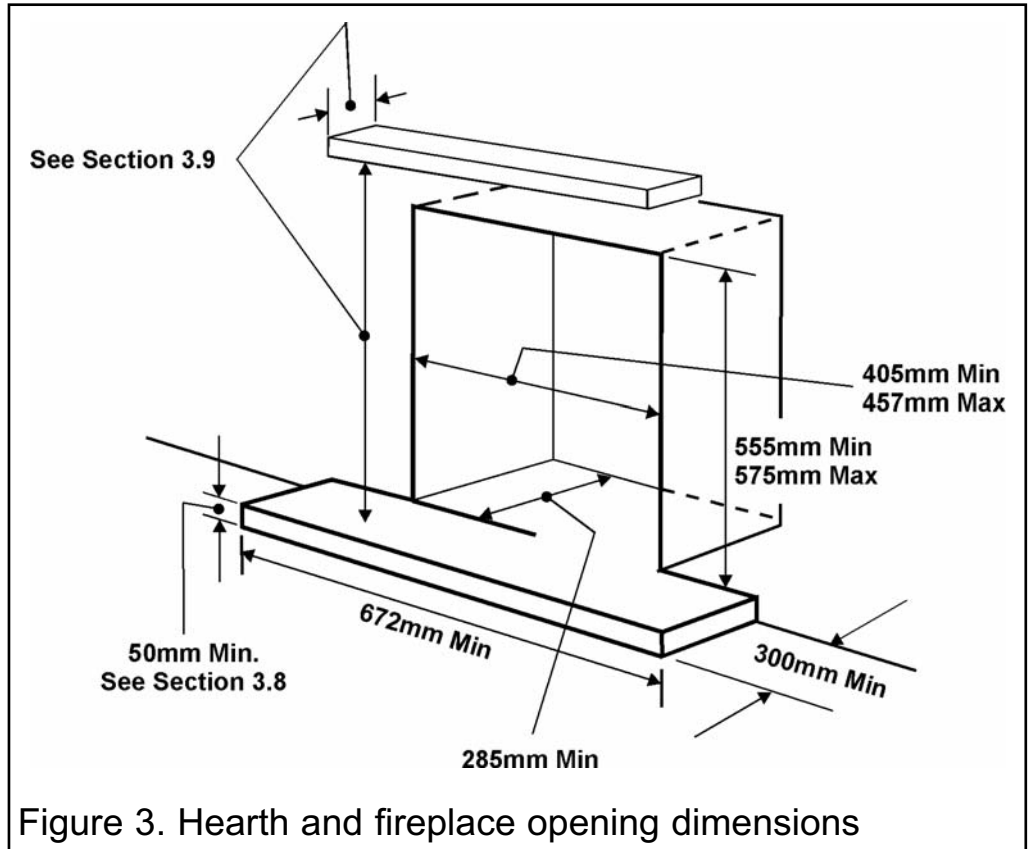

Figure 3. Hearth and fireplace opening dimensions

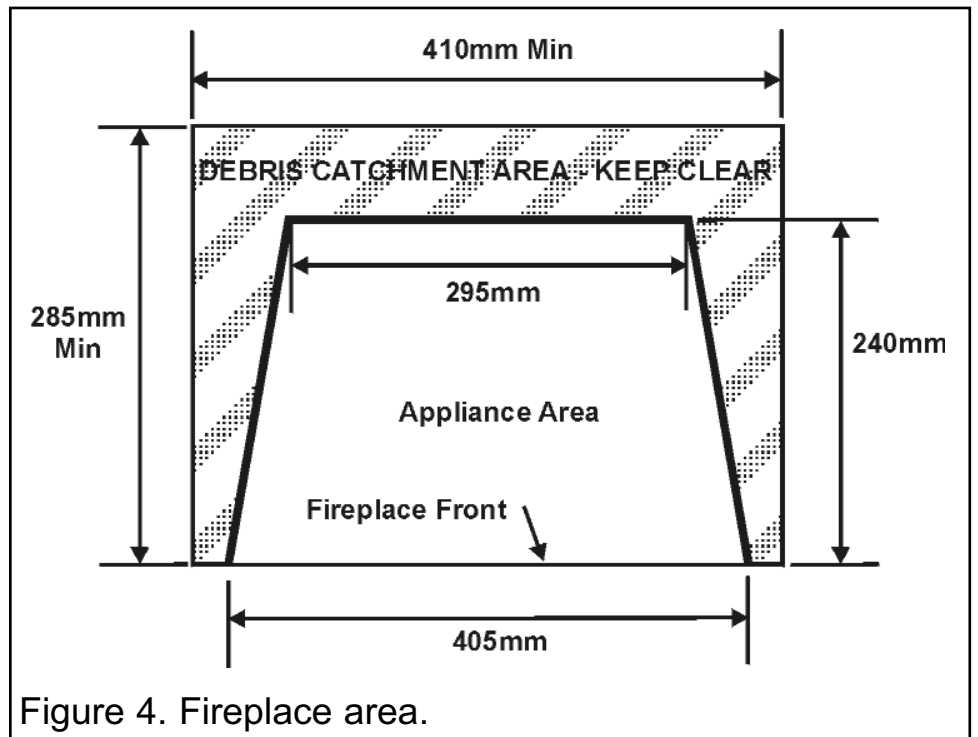

Figure 4. Fireplace area.

3.10.1.1 'Hole-in-the-wall' Installations

It is recommended that a hearth should be installed as in figure 1.

- If fitting a fascia that has a firefront designed to sit on a hearth, a reduced depth hearth is recommended. It is recommended that the reduced hearth has a depth from the fixing plane of the fire of 100mm minimum. This is necessary to support the lower front casting. The heat engine must be installed so that distance from

INSTALLER GUIDE

the base of the fireplace opening in the wall to the finished floor level shall be at least 100mm. Where there is no floor covering or carpet, and the floor is of a type that is likely to be covered in such a way in the future, then the distance from the base of the fireplace opening in the wall to the floor level should be increased to at least 175mm.

- If fitting a fascia that does not have a separate firefront and a hearth is not fitted, the heat engine must be installed so that distance from the base of the fireplace opening in the wall to the finished floor level shall be at least 100mm. Where there is no floor covering or carpet and the floor is of a type that is likely to be covered in such a way in the future then the distance from the base of the fireplace opening in the wall to the floor level should be increased to at least 175mm.
- To protect from the risk of burns and ignition of clothing a tactile separator shall be used. The hearth detailed in section 3.8 meets the requirements for a tactile separator. If this is not used then a 672mm long fender, kerb, horizontal bar, or other barrier, being fixed not less than 50mm above floor level and positioned 300mm in front of the fixing plane of the fire will meet the requirement.

3.10.2 Metal flue box and hearth.

To a fireplace incorporating a metal flue box complying with the constructional requirements of the current edition of BS715. The dimensions of the flue box must conform to those shown in figure 2. The top of the metal flue box must be covered with a 100mm layer of mineral wool or equivalent insulation (See figure 5).

Important Note: Where the flue box has a base sheet that is single wall (i.e. a single metal sheet) the flue box must be mounted on a non-combustible hearth. The hearth material must be at least 12mm thick.

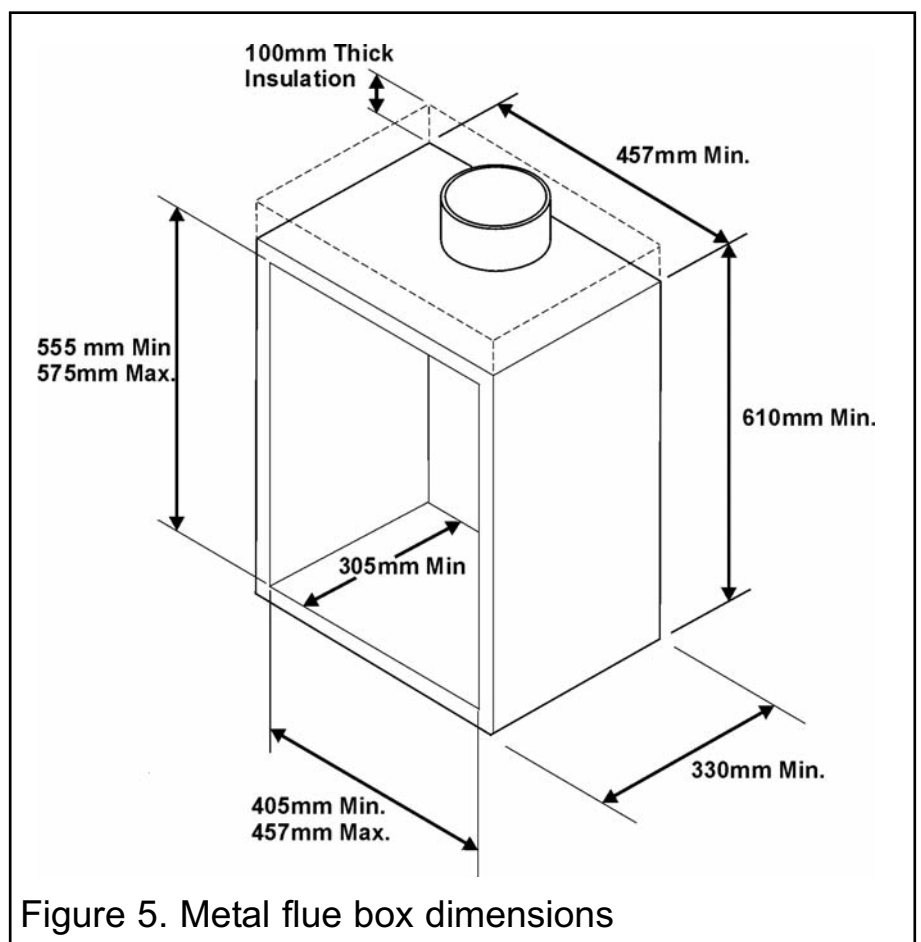

INSTALLER GUIDE

3.10.3 Precast concrete or clay flue block system and hearth.

To a precast concrete or clay flue block system conforming to BS1289 with dimensions as in figure 6. The current versions of BS1289 and BS EN 1858 recommend that there should be an air space or insulation between the flue blocks and the plaster because heat transfer may cause cracking on directly plastered flues. However, generally this appliance is suitable for installations under all circumstances unless there is a history of cracking problems. Remember that faults such as cracking may be caused by poorly built and restrictive flues, e.g. mortar extrusions, too many bends, flue heights below three metres, restrictive terminations etc.

3.11 Flues.

1. Suitable flues and minimum flue sizes are as follows: -

It should be noted that, as with many appliances, sharp bends or horizontal runs in metal flues at the top of the system can be a cause of problems in these types of installation.

- 225mm x 225mm conventional brick flue.
- 175mm diameter lined brick or stone flue.
- 200mm diameter factory made insulated flue manufactured to BS4543.
- 175mm diameter flue pipe. See BS6461 Part 1 for suitable materials.
- Single wall, twin wall or flexible flue liner with a minimum diameter of 125mm. The materials to be used are stainless steel or aluminium as specified in BS EN 1856 Part 1. The liner must be sealed to the surrounding area above the fireplace opening and to the top of the chimney. An approved terminal must be fitted.
- A properly constructed precast concrete or clay flue system conforming to BS1289 or BS EN 1858. This system is only suitable if the conditions stated in section 3.10.3 are met.

2. The flue must conform to BS 5440: Part 1 in design and installation. The flue, measured from the bottom of the fireplace opening to the bottom of the

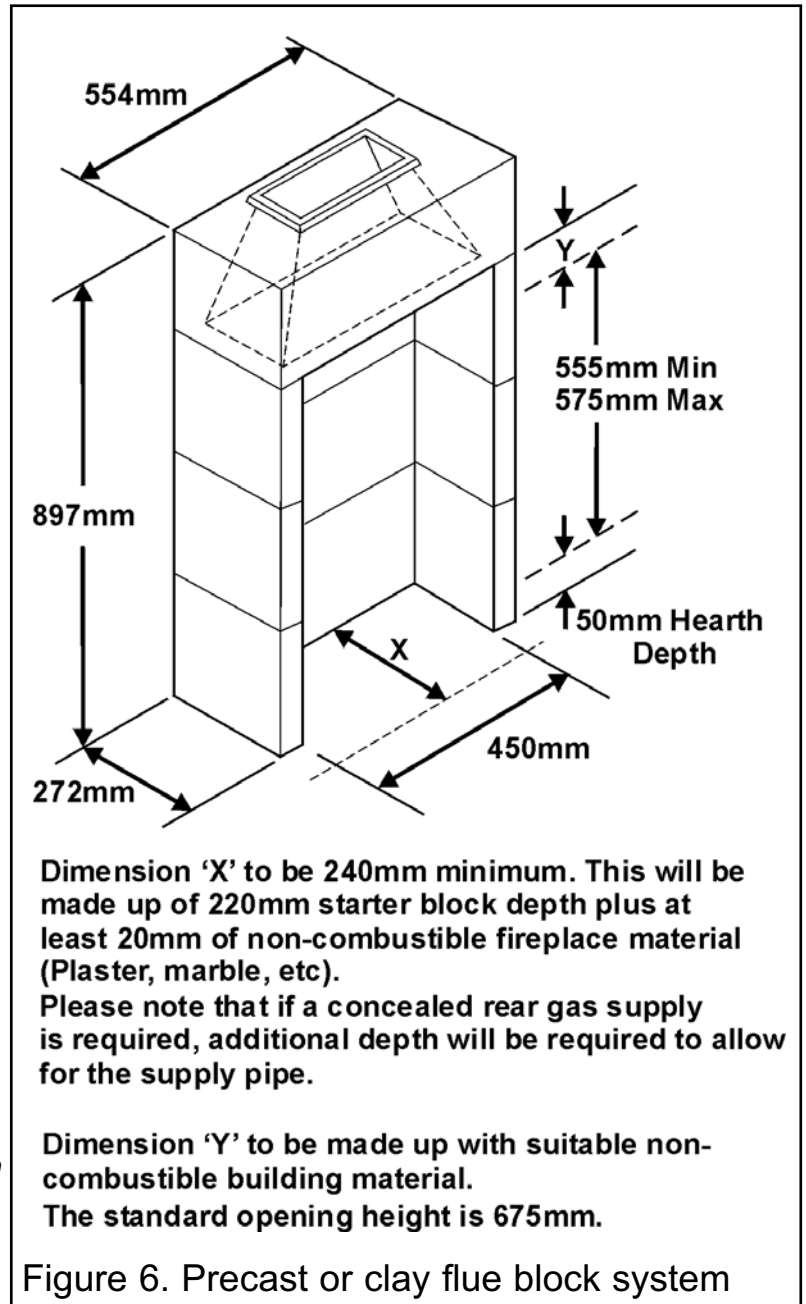

INSTALLER GUIDE

terminal, shall be not less than 3m in actual vertical height. When calculated in accordance with BS 5440: Part 1 Annex A, the minimum **equivalent** height of the flue shall be 2.0m of 125mm dia. flue pipe.

3. The flue must not be used for any other appliance or application.

4. Proprietary terminals must comply with BS 715 or BS 1289. Any terminal or termination must be positioned in accordance with BS 5440 Part 1 to ensure that the products of combustion can be safely dispersed into the outside atmosphere. Where the appliance is connected to an unlined brick chimney it is generally unnecessary for the chimney pot to be replaced or for a terminal to be fitted unless the flue has a diameter smaller than 170mm.

3.12 Propane fires.

Propane gas appliances must not be installed in a room that is built entirely below ground level (See BS 5871 Part 2).

4. PACK CONTENTS

Carefully remove all the contents. Check that all the listed parts are present and in good condition (See figure 7).

Appliance contains:

- 1 Burner & Convection box unit.
- 1 Inlet 'T' connector with pressure test point including nut and olive for 8mm inlet pipe.
- 1 Flue restrictor.
- 3 Screws (For fitting the flue restrictor).
- 1 Rear Ceramic wall support bracket
- 2 Screws (For fitting the rear ceramic wall support bracket).
- 1 Ceramic back wall.
- 1 Pair of ceramic side walls.
- 2 Small "U" seals for the convection box side flanges.
- 1 Strip of floor sealing tape.
- 6 Fibre wall plugs.
- 4 Woodscrews.
- 2 Fire retaining cables.
- 2 Cable clamps.
- 4 Eyebolts.
- 1 Rubber grommet.
- 1 Knurled shouldered screw for control linkage fixing.
- 2 M4 Machine screws (For fascia securing).
- 1 PP3 battery.
- 1 Smoke match tube.
- 1 Length of self adhesive foam seal.

INSTALLER GUIDE

- 1 Canopy shield (This may be supplied with either the fascia or the convection box).
- 3 Screws (For fitting the canopy shield).
- 1 Ceramic fuel effect (Not shown).
- 1 Literature pack.
- 1 Burner tray trim
- 1 Control slider assembly for fascia.
- 2 M4 countersunk screws (For securing control slider to fascia)
- 1 Control position label for fascia.

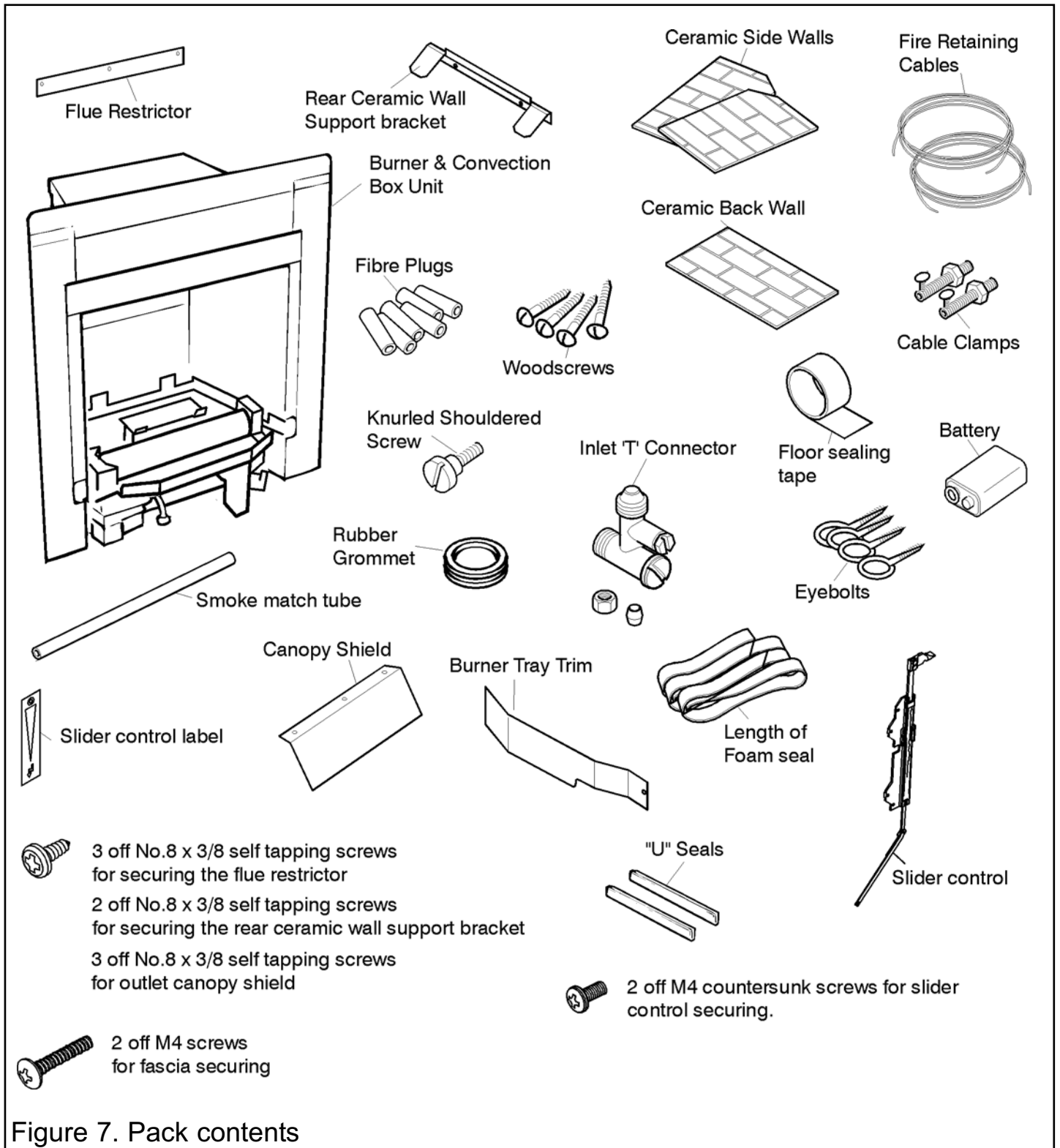

5.1 Soundness for appliance attachment

Two primary methods of retaining the appliance are provided: -

- 1) By fixing to the fireplace front surround.
- 2) Using concealed tension cables fixed to the rear of the fireplace opening together with secondary fixing to the fireplace floor.

The methods are detailed in section 9 of this manual. Before selecting the retention method, consult with the customer. Method 2 is provided for instances where drilling holes in the front surface of the fireplace surround is unacceptable to the customer or otherwise impractical. *N.B. It is unwise to attempt to drill into marble without the proper tools and equipment.*

If method 2 is chosen, make sure that the areas at the back and towards the centre of the fireplace floor are sound enough to take the eyebolts and screws. If these areas have deteriorated due to prolonged use, they should be made sound with suitable cement.

If method 1 is chosen, make sure that the front surround area is sound enough to take the fibre plugs and woodscrews. If necessary, make sound with suitable cement.

5.1.1 Installations using a metal flue box

The whole of the top surface of the metal flue box must be covered with a 100mm layer of mineral wool or equivalent insulation (See figure 5).

5.2 **Fireplace flue pull.**

Close all doors and windows in the room in which the appliance is to be installed. After confirming with a match that smoke is drawn into the flue, light a 13 gram smoke pellet and check that there is a definite flow through the flue. Verify outside that the smoke exits from one terminal only and that the termination is suitable. Observe, where possible, upstairs rooms and loft spaces for signs of escaping smoke indicating a defective flue. If there is not a definite flow warm the flue for a few minutes and repeat the smoke pellet test. If there is still no definite flow the flue may need remedial work – **Do not fit the appliance until there is a definite flow through the flue.**

INSTALLER GUIDE

6. IGNITION CHECK

Before attempting to install, it is worth checking that the electronic ignition system performs satisfactorily.

Fit the battery to the ignition block located below the burner tray at the left side (See figure 8). The locations for the +ve and -ve terminals are marked on the battery holder.

Rotate the control pivot bracket clockwise as far as it will go and hold in this position (See figure 9). This should close the ignition circuit and sparks should be seen tracking from the electrode pin to the pilot tip (See figure 9).

If there are no sparks make the following checks.

- Check condition of battery and that it is correctly fitted.
- If the above is satisfactory, check the ignition circuit and components - see

section 16 which is the servicing and parts replacement section in this guide.

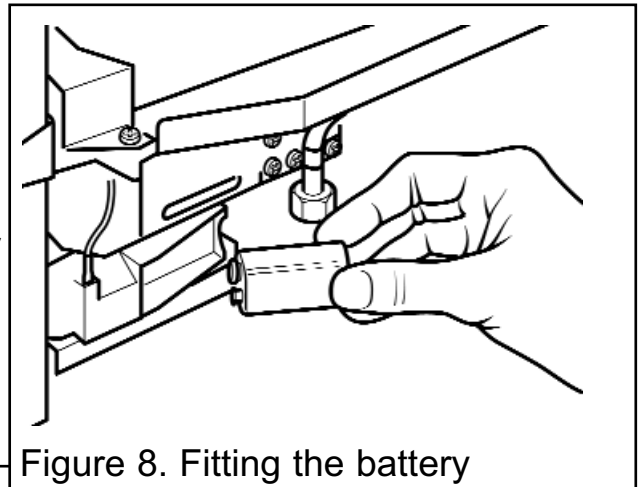

Figure 8. Fitting the battery

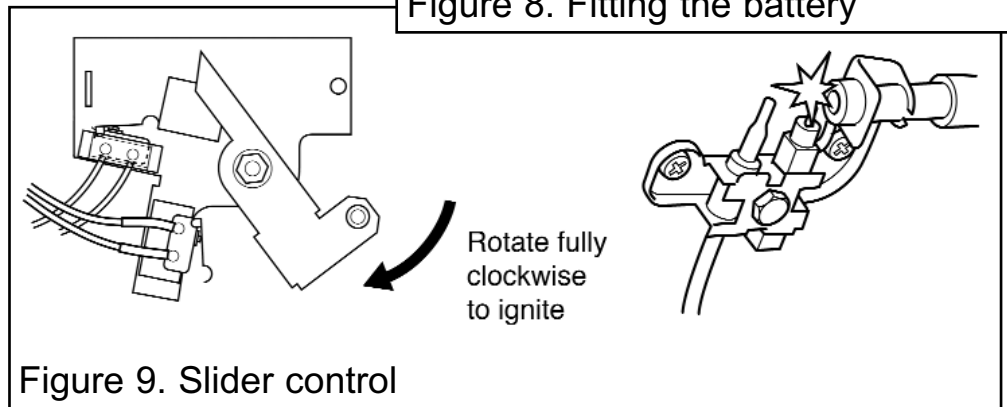

Figure 9. Slider control

7. GAS SUPPLY CONNECTION

A nut and olive are provided for an 8mm pipe inlet connection to the 'T' connector at the bottom front of the appliance. The 'T' connector can be rotated to allow a connection from any direction and includes a valve for isolating the gas supply and a pressure test point.

The supply pipe must be rigid material. Flexible pipe must not be used.

Concealed Supply Pipe Connection.

If a concealed connection from inside the fireplace is required then, **before the appliance is fitted into the fireplace** it will be necessary to extend the supply line so that it will project through the hole in the back of the convection box and run to the 'T' connector at the front. The pipe run from the supply line up to the rear opening in the convection box must be kept away from the area which will be taken by the convection box when it is installed (See figure 4).

Note that the centre of the appliance inlet 'T' connector is 25mm above the fireplace floor. The inlet 'T' connector should be fitted to the supply pipe at this stage.

INSTALLER GUIDE

8. PREPARING APPLIANCE FOR INSTALLATION

1. Detach the burner unit from the convection box by removing two screws (See figure 10). Lift the burner unit clear.

2. Fit the two “U” section seals to the bottom edges of the convection box side flanges (See figure 11).

3. **It is important that the grommet supplied in the loose parts pack is fitted to the hole in the rear of the convection box.**

4. For concealed connection only:

Pierce the grommet to allow the pipe to pass through it. The grommet should envelop the pipe. If the hole is larger than the pipe, seal it with tape. **Do not pierce the grommet unless the supply pipe is to pass through it.**

6. The heat engine or fascia will have a canopy shield supplied with it. Fit this to the convected air outlet of the appliance using the three self tapping screws supplied. The design of the canopy shield may differ from that shown (See figure 12).

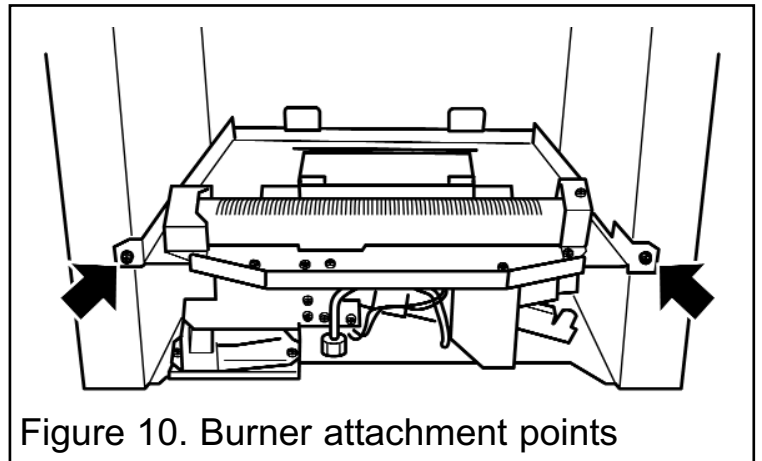

Figure 10. Burner attachment points

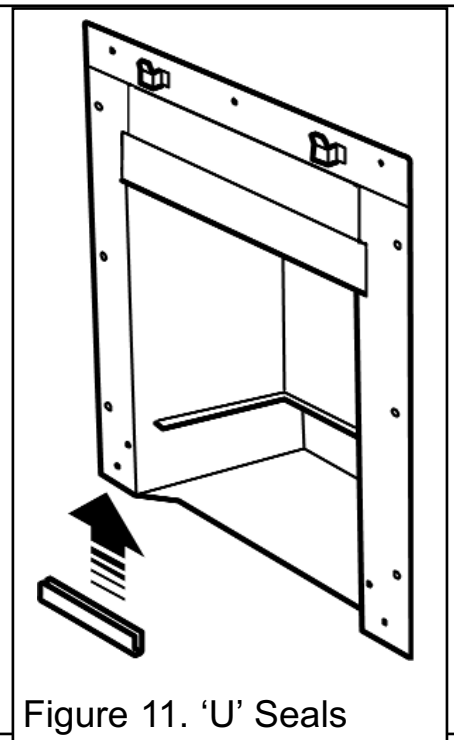

Figure 11. 'U' Seals

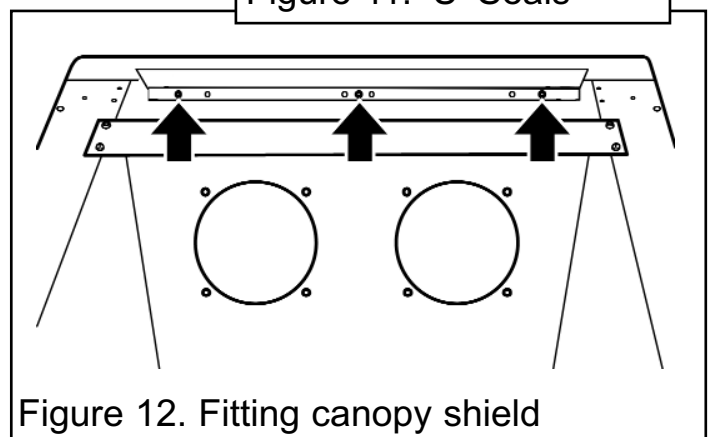

Figure 12. Fitting canopy shield

INSTALLER GUIDE

7. This appliance is supplied with a rear ceramic support bracket. Fit this using two screws supplied (See figure 13).

8. This appliance is supplied with a flue restrictor for use where the flue draught is excessive. The restrictor must NOT be fitted where a precast flue or a flue liner is used. For all other installations the restrictor should be fitted. There may however, be certain exceptional circumstances where fitting the restrictor causes the fire to fail the spillage test. In such cases the restrictor will have to be removed. After removal conduct the spillage check again. The restrictor is packed loose with the appliance and is fixed with three screws (See figure 14).

9. There is a length of self adhesive foam seal supplied with the fire. This will need to be fitted to the outer rear edges of the side and top flanges of the convection box. Cut a 485mm length of foam seal. Be careful not to stretch the seal when measuring. Remove the protective backing from the foam seal and fit this to the rear of the top flange (See figure 15). Cut two 580mm lengths. Fit these to the rear outer edges of the side flanges. Ensure that there is no gap between the foam seals where they meet at the top flange (See figure 15).

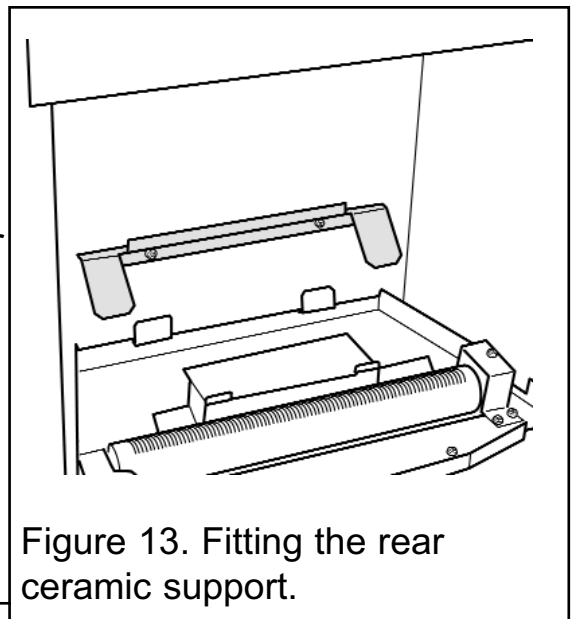

Figure 13. Fitting the rear ceramic support.

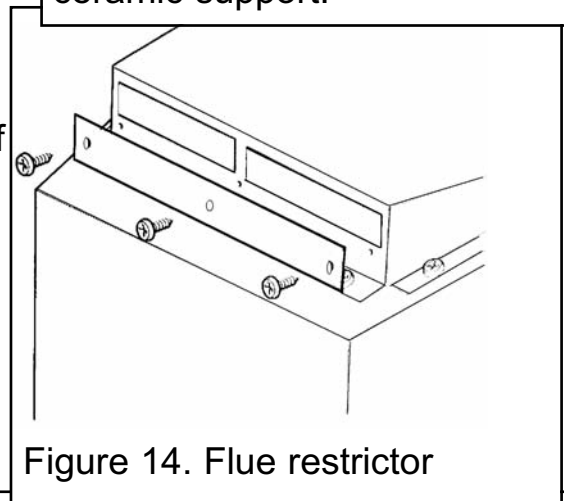

Figure 14. Flue restrictor

The foam seal should touch at this point. Ensure that there is no gap between the seals.

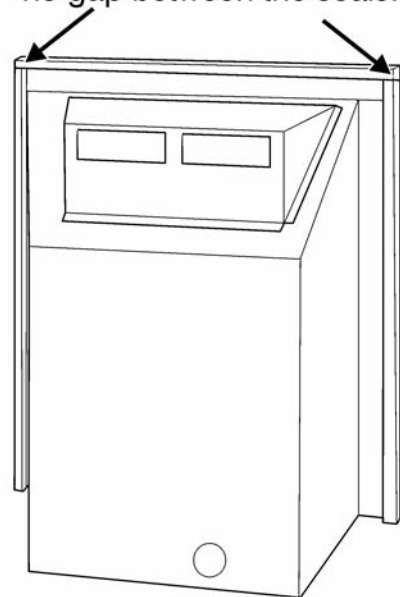

Figure 15. Fitting the foam seal

INSTALLER GUIDE

9. CONVECTION BOX INSTALLATION

9.1 Method 1 - Front fixing to fireplace surround.

1. Make sure that the fireplace front surround area is sound enough to take the fibre plugs and woodscrews. If necessary, make sound with suitable cement.
2. Place the convection box centrally in the fireplace in the position in which it is to be permanently installed. If a concealed connection is being used, insert the convection box into the fireplace feeding the supply pipe through the pierced hole in the rear grommet.
3. Mark the fireplace front surround through the four fixing holes in the side flanges of the convection box (See figure 16).
4. Remove the convection box. Drill four holes in the fireplace front surround at the marked positions using a suitably sized masonry drill for the wall plugs supplied.
5. Insert a fibre plug into each hole.
6. Place the convection box back in position in the fireplace.
7. Fit a woodscrew through each hole in the convection box flanges and tighten to seal the box to the fireplace surround.

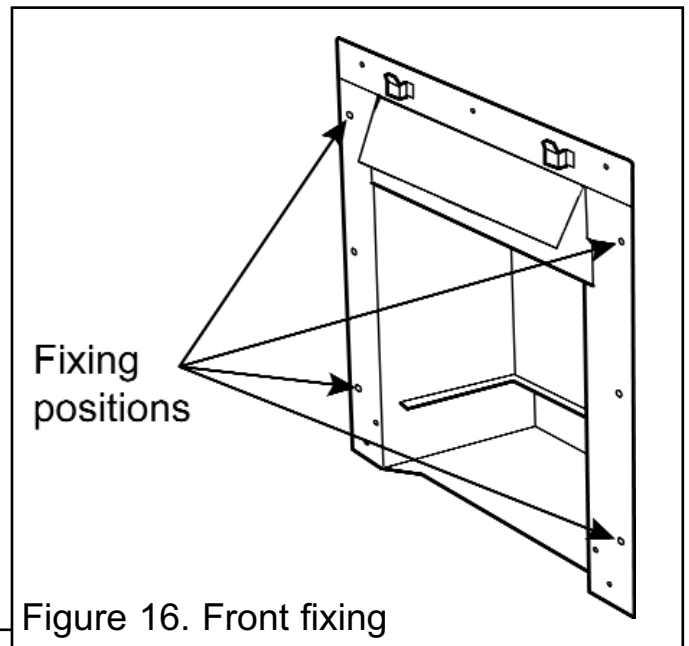
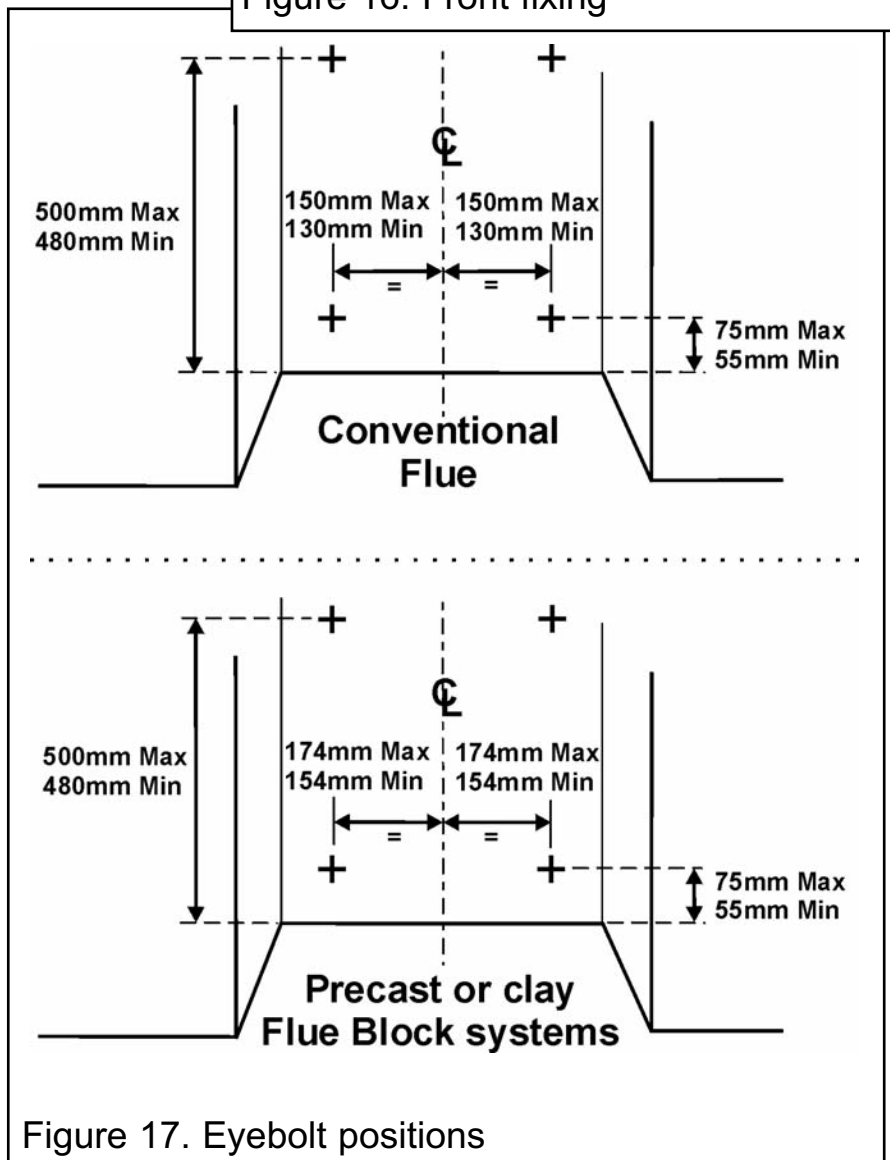

Figure 16. Front fixing

9.2 Method 2 - Cable retention and floor fixing.

1. Make sure that the relevant areas at the fireplace back or floor are sound enough to take the eyebolts and screws. If these areas have deteriorated due to prolonged use they should be made sound with suitable cement.
2. Drill four holes in the rear wall of the fireplace for the eyebolt plugs. The holes should



INSTALLER GUIDE

be drilled within the range of positions shown in figure 17 using a suitably sized masonry drill for the wall plugs supplied. The holes should be equidistant each side of the centre line of the fireplace to ensure that the appliance finishes centrally in the opening when tension is applied to the cables.

3. Insert a fibre plug into each hole. Use the fibre plugs supplied with this appliance - **Never use plastic plugs instead of the fibre plugs supplied.** Screw the eyebolts into the plugs. Make sure that the bolts are secure.

4. Place the convection box unit close to the fireplace but allow sufficient access into the fireplace opening so that the cables can be threaded through the eyebolts and returned through the back of the convection box. If a concealed connection is being used, insert the convection box into the fireplace feeding the supply pipe through the pierced hole in the rear grommet.

5. The convection box has two holes at each side of the convected air opening. Insert one end of each cable (one cable each side) from the back through the lower of the two holes and return the end through the upper of the holes (See figure 18). Give the cables a pull so that they grip against the convection box flanges.

6. Thread the cables through the eyebolts. Return the cables through the holes near the bottom of the convection box back panel (See figure 19) (**For precast or clay block flue systems return the cables through the slotted holes in the side of the convection box**).

7. Place the convection box fully back into the fireplace opening so that it is sealed against the fireplace front surround.

8. Drill a hole into the fireplace floor through each of the two holes in the base of the convection box using a suitably sized masonry drill for the wall plugs supplied (See figure 20).

9. Insert a fibre plug into each hole. Use the fibre plugs supplied with this appliance - **Never use plastic plugs instead of the fibre plugs supplied.** Fit a woodscrew in each plug and tighten.

Always screw the base into position before applying tension to the cables. This will ensure a tight seal between the top of the convection box and wall.

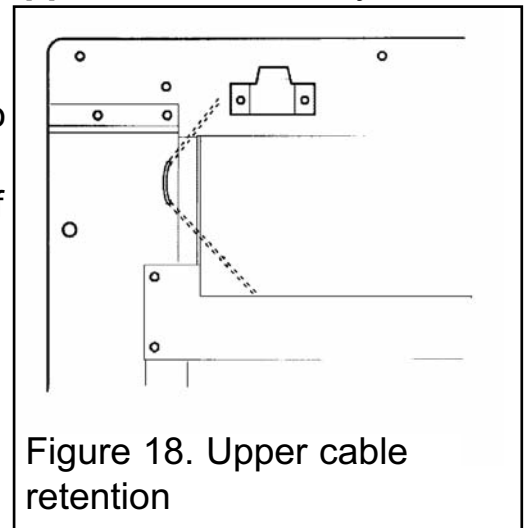

Figure 18. Upper cable retention

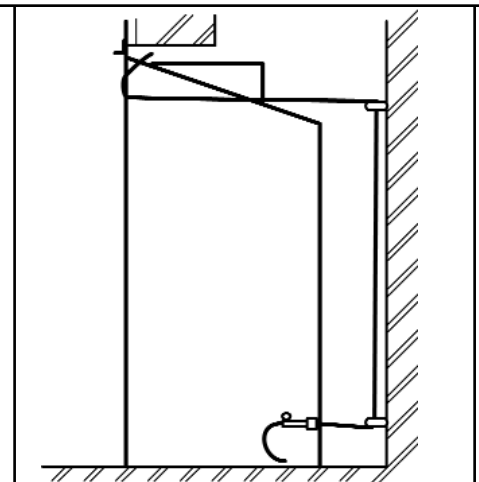

Figure 19. Cable route

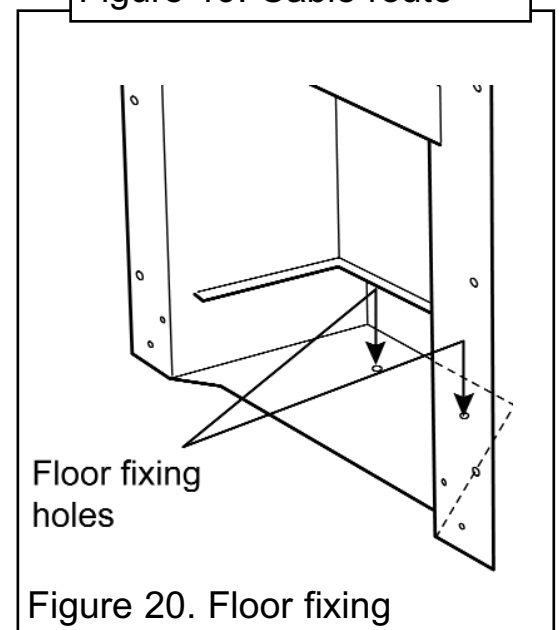

Figure 20. Floor fixing

INSTALLER GUIDE

10. Fit a cable retainer over the bottom end of each cable.

11. Pull each cable taut. Push the cable retainers hard up against the back panel. The end of the cable adjuster will pass into the hole. Tighten the screws in the retainers so that they clamp the cables in position. Apply tension to the cables by turning the hexagonal adjusters by hand (See figure 21).

12. Inspect the installation of the convection box against the fireplace surround. If the convection box is aligned squarely and the sealing is satisfactory, fully tighten the cable retainers.

13. If the convection box is not correctly aligned, release the tension on the cables by slackening the screws and turning the hexagonal adjusters fully anticlockwise. The convection box should then automatically realign itself. Pull each cable taut again and push the cable retainers back against the back panel. Again, tighten the screws in the retainers and apply tension to the cables by turning the hexagonal adjusters clockwise as far as possible.

14. Feed the free length of the cables into the gap between the inner and outer back panels so that they are available to allow easy removal and refitting of the appliance during subsequent service calls. **Do not cut off the free lengths of cable.** On precast flue installations feed the cables into the small holes at the base of the side panels (See figure 21).

9.3 Sealing floor front - all installations.

Using the floor sealing tape supplied, seal the bottom of the convection box to the fireplace and hearth floor (See figure 22).

Make sure that the whole length of the front edge of the convection box is fully sealed.

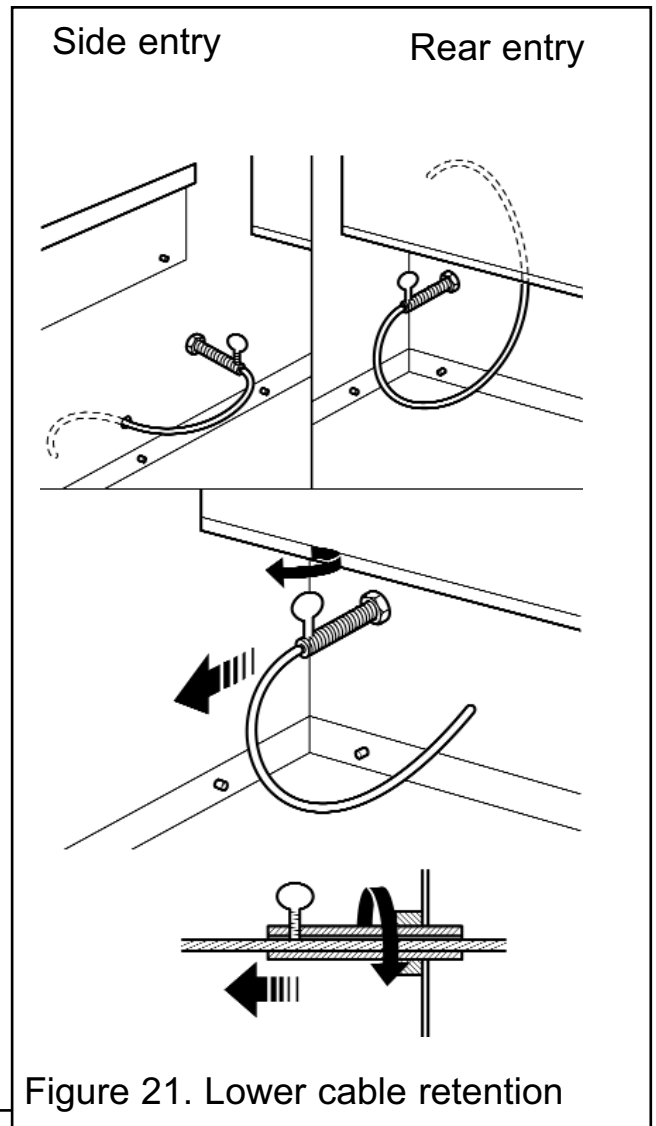

Figure 21. Lower cable retention

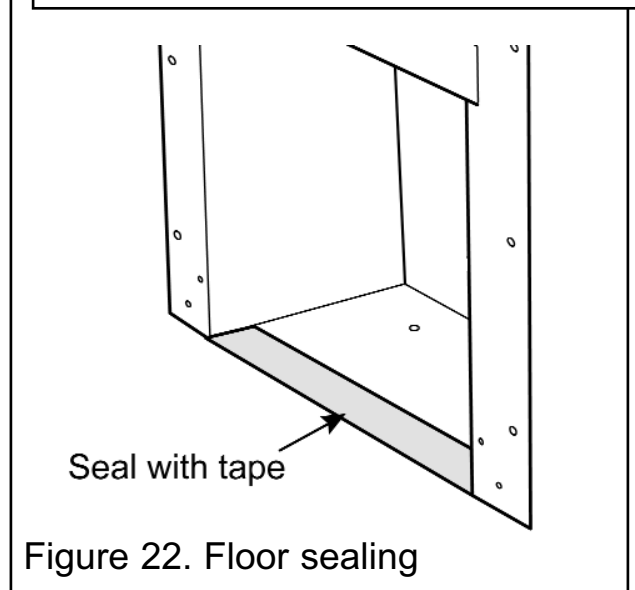

Figure 22. Floor sealing

INSTALLER GUIDE

10. BURNER & SUPPLY PIPE INSTALLATION

10.1 Burner and supply pipe installation.

1. Refit the burner unit to the convection box with two screws.
2. Connect the supply line to the appliance.
3. Turn on the gas supply and pressure check the installation pipework for gas soundness. In the United Kingdom (GB) check in accordance with the current edition of BS 6891. In the Republic of Ireland check in accordance with the current edition of IS 813 "Domestic Gas Installations".
4. Fit the burner tray trim to the front of the burner tray. To do this place the trim against the burner tray with the folded edge at the top rear. Lower the trim so that the folded edge locates over the front face of the burner.

10.2 Preliminary burner checks.

Some burner operations can be checked at this stage. Checking now will mean that less disassembly will be required if any problems are found. **A full check should still be made, however, after final installation.**

1. If closed, open the isolating valve at the inlet 'T' connector.
2. Rotate the control pivot bracket clockwise as far as it will go and hold in this position (See figure 23). This should close the ignition circuit and simultaneously open the gas tap allowing the gas to flow to the pilot. Wait a few seconds while the air is purged. The electronically generated sparks should light the pilot. The pilot should then light the main burner at its low setting. There may be a delay of up to four seconds between the pilot lighting and ignition of the gas at the main burner. This is normal and is due to the time required to fill the main burner compartment with sufficient gas for ignition.
3. When the burner is operating properly, gradually turn the control pivot bracket anti-clockwise. The burner flames should gradually increase until the pivot bracket is nearly at its furthest anti-clockwise rotation. Rotating further until the pivot bracket comes to a stop should then turn the burner and pilot off.
4. If the above checks are satisfactory, continue with the installation. If not, check the control and ignition circuitry and components as described in the servicing section of this guide.

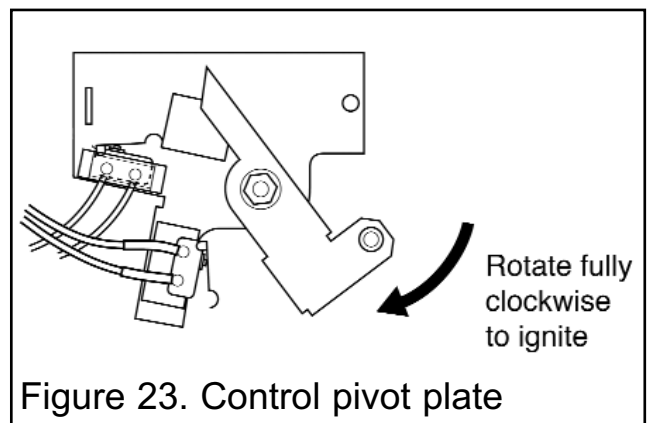

Figure 23. Control pivot plate

INSTALLER GUIDE

10.3 Inlet pressure check.

The appliance is pre-set to give the correct heat input at the inlet pressure shown in section 2 of this manual. No adjustment is necessary.

1. Ensure that the fire is turned OFF before removing the pressure test point sealing screw. Check the inlet pressure by fitting a pressure gauge at the test point. The test point is on the inlet 'T' connector (See figure 24). Check the pressure with the appliance alight and set at maximum output.

2. After checking, turn off the appliance. Remove the pressure gauge and replace the test point sealing screw.

3. Test around the sealing screw for gas soundness with a suitable leak detection fluid.

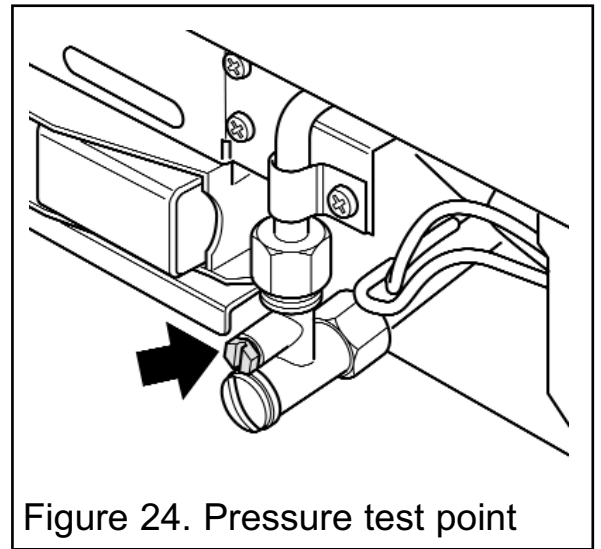

Figure 24. Pressure test point

When the above checks from section 10.2 and 10.3 have been completed, turn the appliance OFF and close the isolating valve on the inlet 'T' connector. This will prevent any accidental gas flow / ignition whilst fitting the ceramic fuel effect and fascia.

11. CERAMIC WALLS INSTALLATION

1. Fit the ceramic rear wall inside the "L" bracket on the back face of the burner compartment. Push the ceramic wall flat against the back face of the burner compartment (See figure 25).

2. Remove four screws from the spillage plate sides (See figure 26).

3. Remove the spillage plate by lifting it forward.

4. Fit the ceramic side walls against the side faces of the burner compartment. The bottom edges of the walls should rest in the ledges at the sides of the firebox. Slide them in from the front and ensure that they touch the rear wall. The friction between the side walls and the rear wall should hold the side walls in position (See figure 26).

5. Re-fit the spillage plate. Be careful not to damage the edges of the side walls. The spillage plate will hold the side walls in place.

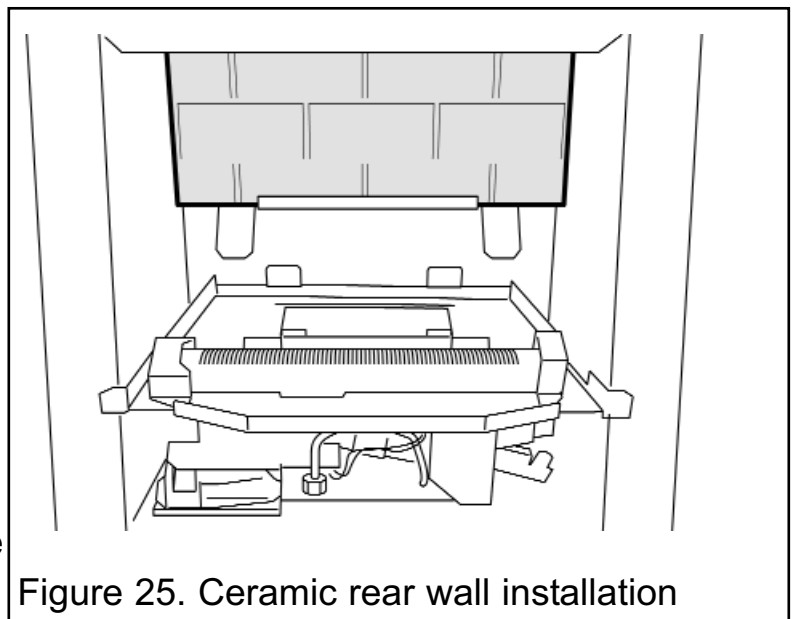

Figure 25. Ceramic rear wall installation

INSTALLER GUIDE

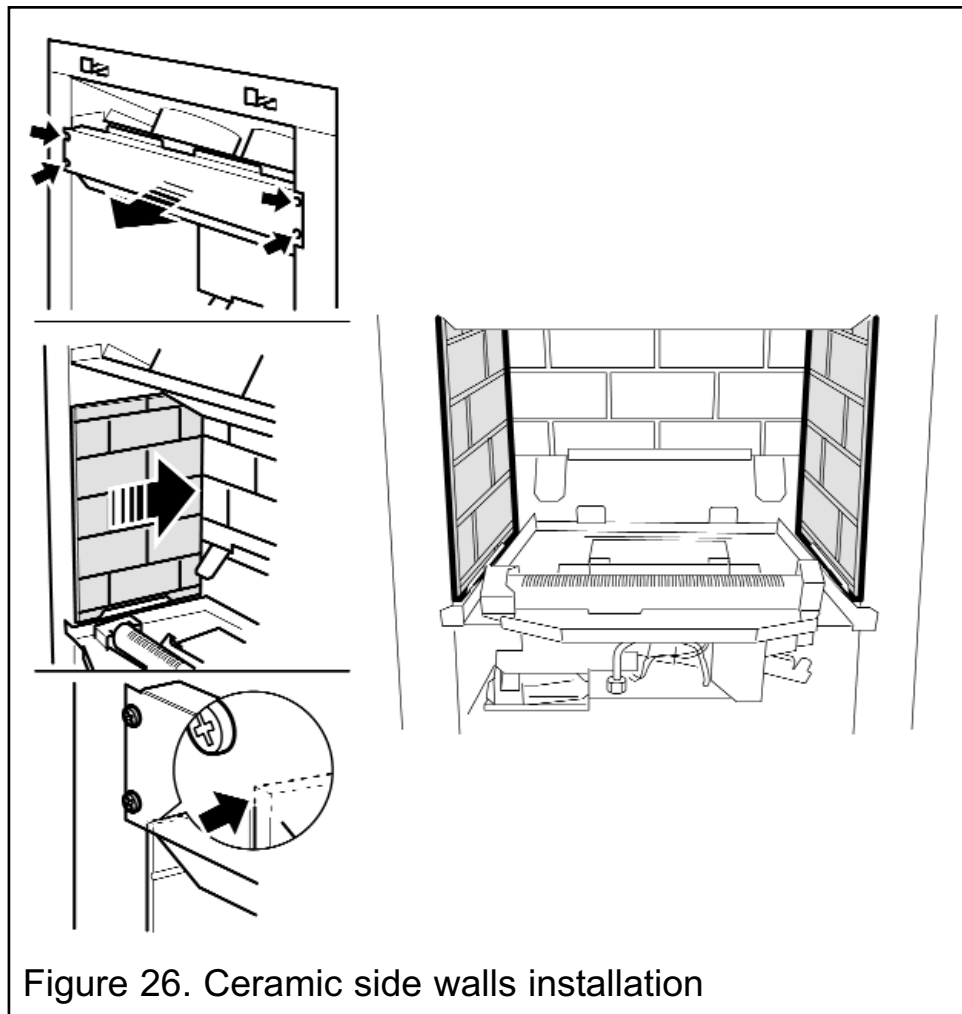

Figure 26. Ceramic side walls installation

12. FITTING THE CERAMIC FUEL EFFECT

The fitting guide for the ceramic fuel effect is supplied with the ceramic fuel effect. It is important that the fitting guide for the ceramic fuel effect be placed inside or attached to this guide and handed to the customer following completion of the 'final review' section.

Ensure that the fire is OFF. Open the isolating valve at the inlet 'T' connector and replace the end cap. Light the fire, turn to the maximum output position and test around the sealing screw for gas soundness with a suitable leak detection fluid.

INSTALLER GUIDE

13. FITTING THE FASCIA

There is a self adhesive control position label and control slider assembly supplied with this fire. These should be fitted to the fascia as shown in the fascia fitting guide. The fitting guide for the fascia is supplied with the fascia and the fascia should be fitted in accordance with it.

14. FULL OPERATING CHECKS

14.1 Check the control settings.

The control position markings on the fascia are shown in figure 27.

Please note:

- *When first turned on from cold, the flames will appear predominantly blue.*
- *When operating the fire for the first time, some vapours may be given off which could set off smoke alarms in the vicinity. These vapours are quite normal with new appliances. They are totally harmless and will disappear after a few hours use.*

1. Make sure the slider button is at the off position (At topmost position marked "O" on the fascia).
2. Open the isolating valve on the inlet 'T' connector.
3. Slide the button to the bottom (ignition) position marked

 . Retain in this position to ignite the pilot. The burner

should ignite at its lowest setting within 4 seconds of the pilot igniting. Keep at this position for a further 10 seconds to allow the pilot flame to stabilise.

4. Release the button. The button should automatically spring up to the low heat position. If for any reason the slider control does not spring up, raise the slider to the topmost (Off) position and investigate why the slider is not operating correctly. If the flames go out at this stage or when checking the rest of the setting positions, try the full lighting sequence again. If the flames fail after two attempts, investigate the pilot unit.

5. Gradually slide the button up to increase the burner setting. The burner should be at its maximum setting at the high heat position shown in figure 27. You should feel a check to the button movement at this position.

6. Slide the control button up past the high heat position to the off ("O") position at the top of the slide slot. Both pilot and main burner should go out. While cooling the ceramic fuel effect may make some crackling noises. This is quite normal.

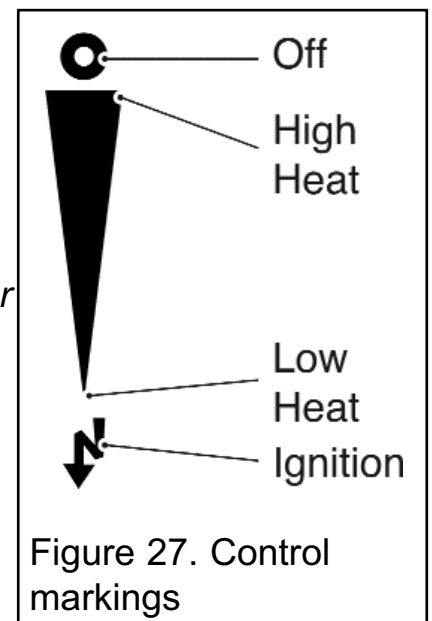

INSTALLER GUIDE

14.2 Check for spillage.

A spillage check must be made before leaving the installed appliance with the customer. Make this with all the ceramic fuel effect pieces and complete fascia in position.

1. Close all doors and windows in the room containing the appliance.
2. Light the appliance and set the slide control to the maximum burning position.
3. Leave the appliance on for five minutes.
4. The smoke match should be placed horizontally into the convection box at the right hand side. There is a notch in the black cross member. Insert the tube so that the neck of its flared end is 5mm passed and in contact the cross member (See figure 28).

The installation is satisfactory if the smoke is drawn into the appliance. If the smoke is not drawn into the appliance leave the appliance alight at the maximum setting for a further ten minutes and then repeat the test. If the smoke is still not drawn into the appliance inspect the sealing to the fireplace surround. If the sealing is satisfactory but the appliance is installed with the flue restrictor (See section 8 point 8) remove the restrictor, reseal the appliance and retest. If smoke is still not drawn into the appliance **disconnect the appliance and seek expert advice.**

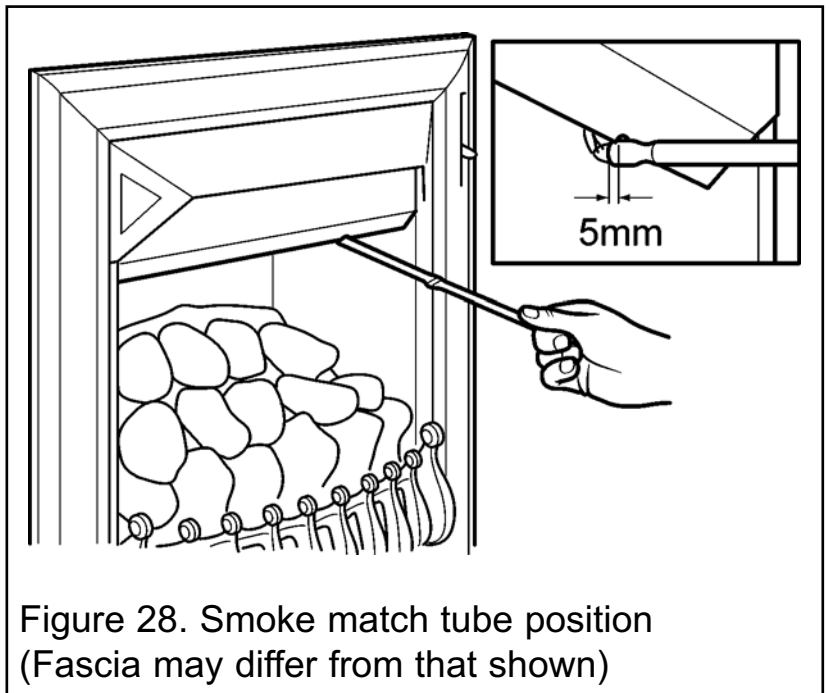

Figure 28. Smoke match tube position
(Fascia may differ from that shown)

5. If the above test is satisfactory open all internal connecting doors, hatches, etc. in the room. Keep all doors and windows that open to the outside of the building closed. Recheck for spillage as above. If an extractor fan is installed in the same room as the appliance or a connecting room, check that spillage does not occur with the fan operating and all doors and other openings between the fan and the appliance open. If the smoke is drawn into the appliance, continue with the installation. If the test is not satisfactory **disconnect the appliance and advise the customer of the cause of failure.**

14.3 Flame supervision and spillage monitoring system.

This pilot unit includes a system that will automatically shut off the gas supply if the pilot flame goes out or if there is insufficient oxygen due to spillage or poor ventilation. Check that the system operates properly as follows;

1. Light the appliance. Set the slide control to the maximum burning position and

INSTALLER GUIDE

leave for one minute.

2. Set the control to the Low burning position. Isolate the gas supply at the inlet 'T' connector. The pilot and main burner will go out. **Note the time when the pilot goes out.** Listen for a snap sound at the gas tap. **Note the time when the sound is heard.** This sound is caused by an electromagnetic valve shutting off the gas supply through the tap. The valve is located in the body of the tap. The valve should operate **within 60 seconds of the pilot going out.** If the valve does not operate within this time limit do not allow the appliance to be used until the fault has been corrected. **This monitoring system must not be adjusted, bypassed or put out of operation.**

This monitoring system, or any of its parts, must only be exchanged using authorised parts.

3. Open the isolating valve on the inlet 'T' connector. Screw on the end cap and test for leaks.

4. Set the slider to the "Off" position.

15. FINAL REVIEW

1. If a gap is visible between the inner sides of the fascia and the ceramic side walls, gently slide the walls forward.

2. Visually inspect the appliance. Clean off any marks incurred during installation.

3. Advise the customer how to operate the appliance. Point out that lighting instruction details are on the information label attached at the bottom of the appliance. Explain to the customer that the appliance has a flame failure & spillage monitoring system. Point out the explanation of this system shown in the owner guide under "Operating the fire". Advise that if the fire goes out for any reason, wait at least three minutes before relighting. Stress that if the monitoring system repeatedly shuts off the fire, the appliance should be switched off and a specialist should be consulted.

4. Advise the customer that they should read their owner guide before operating the fire and always follow the advice in the section headed "Cleaning your fire".

Stress that no extra ceramic fuel effect pieces must be added over and above those supplied with the appliance and that any replacements must only be the authorised spares. Warn that ignoring this advice could cause incomplete clearance of the products of combustion with consequent health hazards.

6. Advise the customer that the appliance will operate to its maximum potential if the flue is primed during the first 20 – 30 minutes of use. To do this, simply slide the control to its highest setting. This will also burn off any carbon deposits that may have formed during previous use.

If using the appliance for long periods it is beneficial to change between settings. This will also help to remove any carbon deposits that may form during use.

7. Recommend that the appliance should be serviced by a competent person at least annually.

8. If the appliance is in premises in the United Kingdom occupied by a tenant, point

INSTALLER GUIDE

out that by law a landlord must have any gas appliance, flue and pipework which is situated in a tenant's premises checked for safety at least every 12 months.

9. Advise that the fire may give off a slight odour while new. This is quite normal and it will disappear after a short period of use.

10. Inform the customer that the Serial number for the appliance is located on the information label located behind the firefront and underneath the burner module.

11. Hand the literature pack with this guide to the customer.

16. SERVICING & PARTS REPLACEMENT

Always turn off the gas supply and allow to cool completely before commencing any servicing (The appliance inlet 'T' connector incorporates an isolating valve).

It is recommended that, at least once a year, the appliance is disconnected and the fireplace opening checked and cleared of any debris.

This product uses fuel effect pieces and burner compartment walls containing Refractory Ceramic Fibres (RCF), which are man-made vitreous silicate fibres. Excessive exposure to these materials may cause irritation to eyes, skin and respiratory tract. Consequently, it is important to take care when handling these articles to ensure that the release of dust is kept to a minimum. To ensure that the release of fibres from these RCF articles is kept to a minimum, during installation and servicing we recommend that you use a HEPA filtered vacuum to remove any dust and soot accumulated in and around the fire before and after working on the fire. When replacing these articles we recommend that the replaced items are not broken up, but are sealed within a heavy duty polythene bag, clearly labelled as RCF waste. RCF waste is classed as a stable, non-reactive hazardous waste and may be disposed at a landfill licenced to accept such waste. Protective clothing is not required when handling these articles, but we recommend the use of suitable gloves to prevent irritation. We also recommend you follow the normal hygiene rules of not smoking, eating or drinking in the work area and always wash your hands before eating or drinking.

This appliance does not contain any component manufactured from asbestos or asbestos related products.

- Check that the appliance is clean and that soot or debris is not blocking the gaps between the ceramic fuel effect pieces causing an imperfect flame.
- Check that soot or debris is not impairing the electrode spark or pilot burner.
- Check that soot or debris is not blocking any of the slots in the main burner.
- After servicing, make sure that the ceramic walls are replaced correctly as described in this guide and the ceramic fuel effect pieces are replaced correctly as described in the installer and owner guide supplied with the ceramic fuel effect. The ceramic fuel effect guide may have been placed inside or attached to this guide.
- **Always test for gas soundness and spillage after servicing the appliance.**

INSTALLER GUIDE

16.1 Checking the aeration setting of the burner.

1. The aeration shutter is factory set and should not require adjustment. If the shutter is not as shown in figure 29 and requires adjustment, loosen the two aeration shutter screws, slide the aeration shutter to the position shown in figure 29 and tighten the fixing screws.

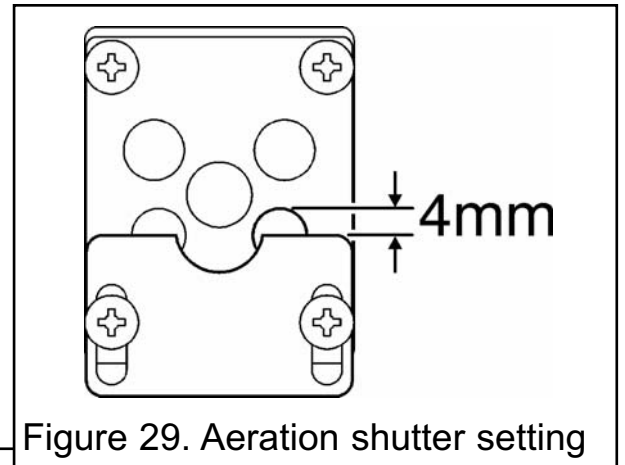

Figure 29. Aeration shutter setting

16.2 To remove the ignition microswitch.

(See figures 30 & 31).

1. Remove the firefront from the fascia
2. Disconnect the leads from the ignition microswitch (The lower of the two microswitches - See figure 30).
3. Detach the microswitch and insulation pad by removing two screws.
4. Replace in the reverse order. Check that the microswitch operates correctly by fully closing it and observing that there are sparks at the pilot electrode.

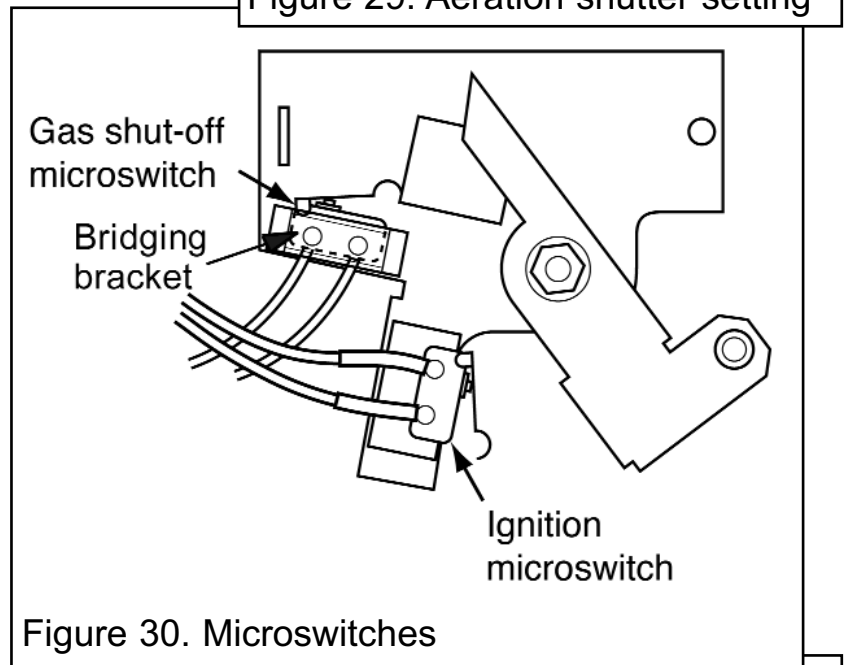

Figure 30. Microswitches

16.3 To remove the gas shut-off microswitch.

See figures 30 & 31.

1. Remove the bottom front cover and the fire front.
2. Loosen the thermocouple nut to free the microswitch leads and pull the leads clear of the thermocouple interrupter block (See figure 31).
3. Detach the bridging bracket, microswitch assembly by removing two screws (See figure 30).
4. Replace in the reverse order. When refitting the leads to the interrupter block, make sure that they are secured firmly to give a good electrical contact.

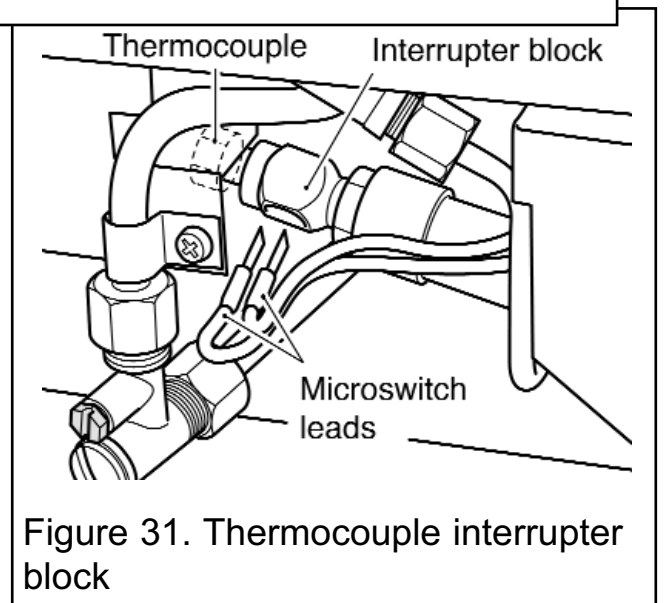

Figure 31. Thermocouple interrupter block

16.4 To remove the fascia.

Remove the fascia in the reverse order to that shown in the fascia fitting guide. The fascia fitting guide is supplied with the fascia and should be left inside or attached to this guide.

Always remember to remove the control linkage screw (See figure 32).

INSTALLER GUIDE

16.5 To replace the control slide unit.

1. Remove the fascia (See section 16.4).
2. Detach the slide unit by removing two screws securing the plastic slide mechanism to the rear of the fascia (See figure 33).
3. Replace in the reverse order.

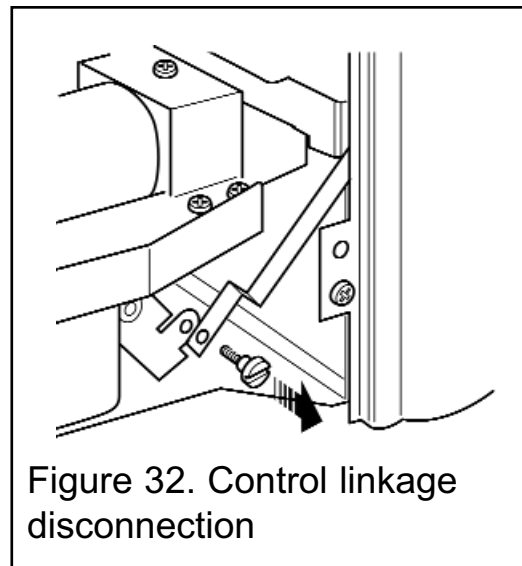

16.6 To replace the control slide button.

1. Remove the fascia (See section 16.4).
2. Remove the control slide unit (See section 16.5)
3. Detach the slide button by removing two screws.
4. Replace in the reverse order.

16.7 To remove the burner unit.

1. Remove the fire front and fascia - See section 16.4.
2. Remove the loose ceramic fuel effect pieces, the front ceramic fuel effect and the base ceramic fuel effect.
3. Close the isolating valve in the inlet 'T' connector. Support the inlet 'T' connector to avoid straining the pipework and disconnect the appliance from the 'T' connector.
4. Detach the burner unit from the convection box by removing two screws (See figure 34).
5. Replace in the reverse order.

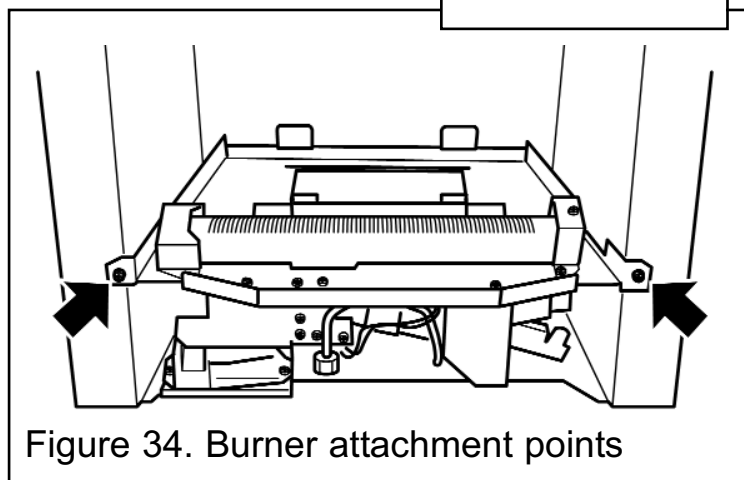
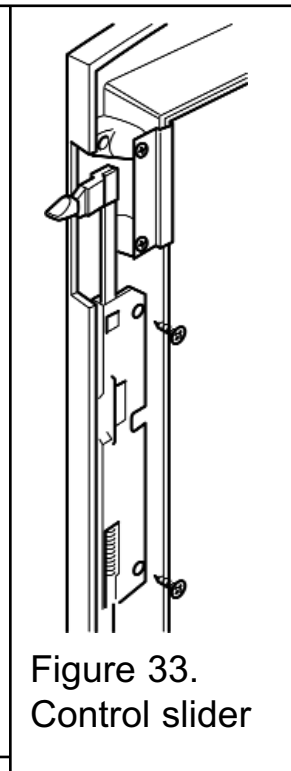

INSTALLER GUIDE

16.8 To remove the electronic ignition generator.

1. Remove the firefront.
2. Remove the loose ceramic fuel effect pieces, the front ceramic fuel effect and the base ceramic fuel effect.
3. Remove the battery.
4. Remove the spark lead.
5. Unscrew the four support bracket screws (See figure 35). The generator and its support bracket can now be moved forward. Be careful not to apply tension to the microswitch leads.
6. Remove the two fixing screws that attach the generator unit to the support bracket. The igniter generator can now be removed (See figure 35).
7. Remove the two leads to the switch and remove the spark lead. If necessary, mark them to ensure that they are replaced on to the correct terminals.
8. Replace the generator
9. Refit in the reverse order.

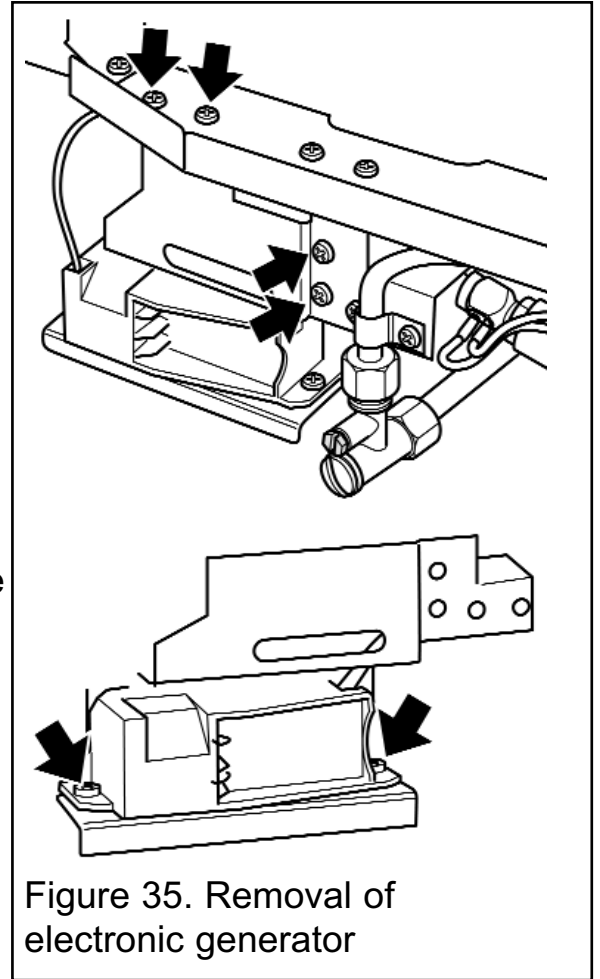

Figure 35. Removal of electronic generator

16.9 To remove the thermocouple interrupter block.

(See figure 36).

1. Remove the burner unit - See section 16.7.
2. Detach the thermocouple from the interrupter block by unscrewing the thermocouple nut.
3. Detach the two microswitch leads from the interrupter block.
4. Remove the interrupter block by unscrewing from the gas shut-off tap.
5. Refit in the reverse order. If the microswitch leads cannot be easily attached to the interrupter block when it is fully tightened to the gas shut-off tap, slacken it and rotate to allow the leads to be fitted. Retighten making sure that the leads remain in place in the interrupter block. Fit and tighten the thermocouple nut making sure that the leads are secured in the interrupter block to give a good electrical contact.

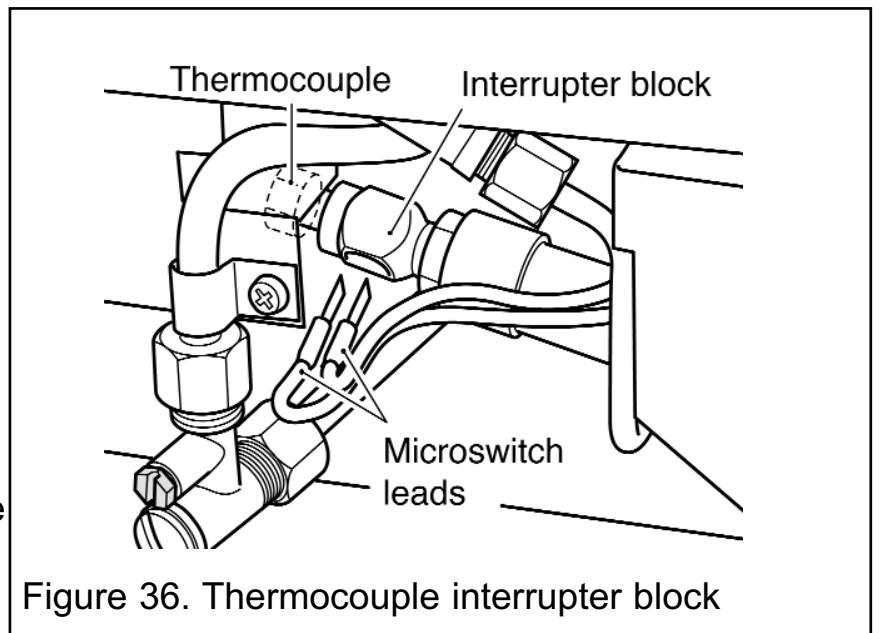

Figure 36. Thermocouple interrupter block

INSTALLER GUIDE

16.10 To remove the pilot unit.

1. Remove the burner unit - See section 16.7.
2. Detach the pilot pipe from the pilot unit.
3. Detach the thermocouple from the interrupter block by unscrewing the thermocouple nut.
4. Detach the electrode lead from the underside of the electrode tab.
6. Remove the two screws securing the pilot unit (See figure 37).
7. Refit in the reverse order.

Note: 1. The pilot unit is an atmosphere sensing device. It must be replaced as a whole assembly. Its individual components are not separately replaceable.

2. When the thermocouple is removed from the interrupter block, the microswitch lead terminals in the interrupter block will be loose. Make sure that they are properly secured to give a good electrical contact when retightening the thermocouple nut.

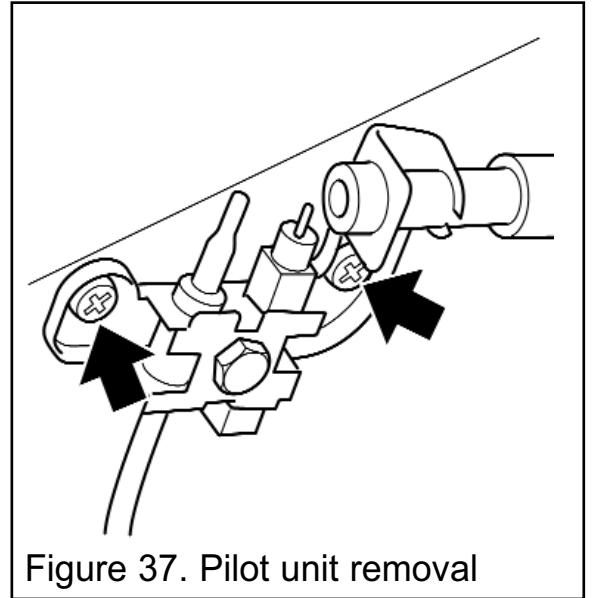

Figure 37. Pilot unit removal

16.11 To remove the shut-off tap.

(See figure 38).

1. Remove the burner unit - See section 16.7.
2. If lying the burner on its back, ensure that the work surface is suitably protected. This will avoid damage to the work surface. Turn the burner unit upside down. Detach the thermocouple and interrupter block from the tap - See section 16.9 paragraphs 2 - 4.
3. Detach the pilot pipe from the tap.
4. Detach the inlet pipe.
5. Remove the hexagonal nut securing the tap to the mounting bracket.
6. Detach the elbow by unfastening the hexagonal nut connecting it to the flow rate controller. Lift the tap (complete with elbow) clear.

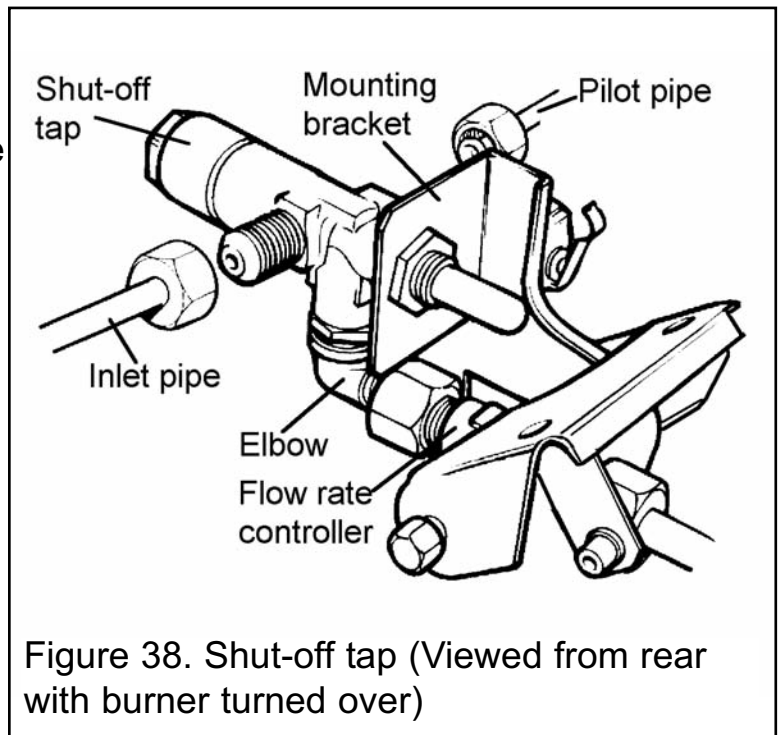

Figure 38. Shut-off tap (Viewed from rear with burner turned over)

7. Loosen the hexagonal locknut securing the elbow to the tap. Remove the elbow by rotating it.
8. If fitting a new tap, remove the hexagonal nut at the mounting bracket end of the old tap and fit to the replacement tap. Refit in the reverse order. When refitting, make sure that the tap spindle is in the correct relationship relative to the control pivot

INSTALLER GUIDE

bracket. Rotate the pivot bracket fully clockwise. The tap spindle should “bottom out” (i.e. the tap should be fully open) after the pivot bracket has actuated the ignition microswitch but before it has pushed the microswitch leaf against the microswitch body.

When refitting the thermocouple and interrupter block, make sure that the microswitch wires are properly secured to give a good electrical contact.

16.12 To remove the gas flow rate controller.

(See figure 39).

1. Remove the burner unit - See section 16.7.
2. If lying the burner on its back, ensure that the work surface is suitably protected. This will avoid damage to the work surface.
3. Detach the shut-off tap as detailed in section 16.11 paragraphs 2-6.
4. Detach the burner pipe from the controller. Support the controller while detaching to prevent excessive strain.
5. Remove the nut and washer securing the control pivot bracket to the controller at the front. Support the pivot bracket while removing the nut to prevent possible damage to the microswitch.
6. Remove the hexagonal bolt securing the control pivot bracket to the controller at the rear.
7. Detach the control pivot bracket.
8. Remove the hexagonal nut securing the controller to the front mounting bracket and remove the flow rate controller.
9. Refit in the reverse order.

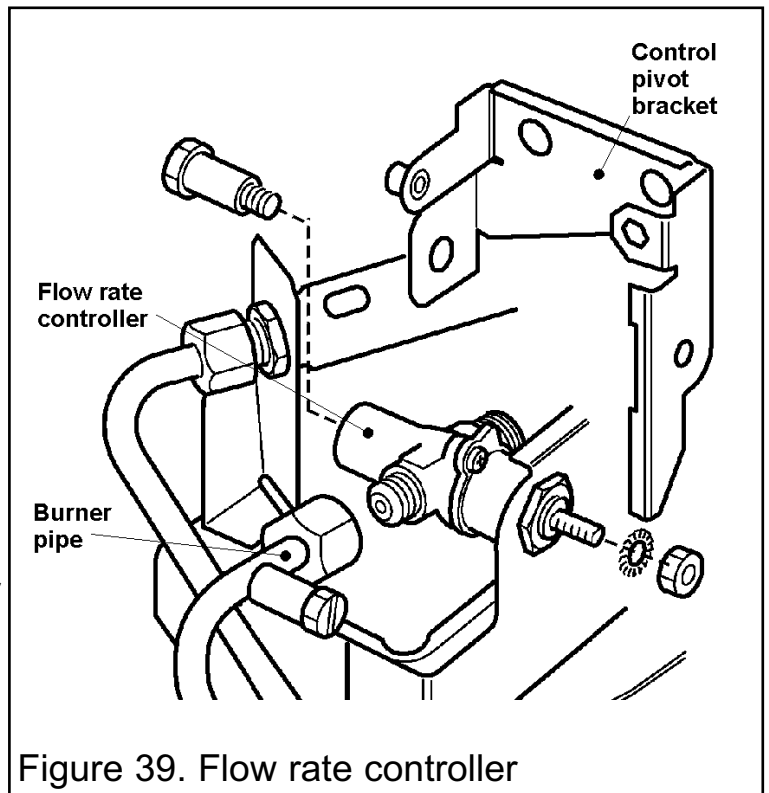

Figure 39. Flow rate controller

16.13 To replace the burner.

(See figure 40).

1. Remove the burner unit - See section 16.7.
2. Support the elbow injector and unscrew the injector nut.
3. Remove the two screws from the burner clamping plate (See figure 40)
4. Lift the right hand side of the burner, slide it to the right and lift clear
5. Refit in reverse order.

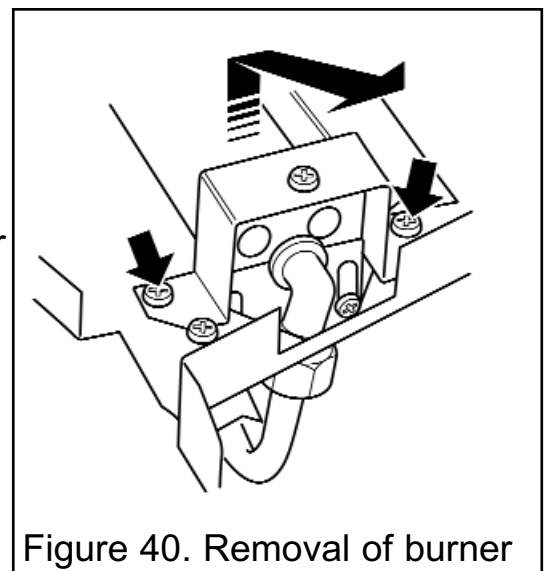

Figure 40. Removal of burner

INSTALLER GUIDE

16.14 To remove the main burner injector.

(See figure 41).

1. Remove the burner - See section 16.13.
2. Remove the burner clamping screw (See figure 41).
3. Unscrew the injector from the burner.
4. Refit in the reverse order.

16.15 To remove the appliance from the fireplace.

1. Remove the burner unit - See section 16.7.
2. If the fire retention is as method 1 (See section 9.1 of installation instructions), remove the screws.
If the fire retention is as method 2 (See section 9.2 of installation instructions), slacken the hexagonal adjusters on the cable retainers and unscrew the thumbscrews to release the cables.
3. Refit as described in the relevant installation sections. Make sure gas soundness, sealing, spillage test and performance are satisfactory.

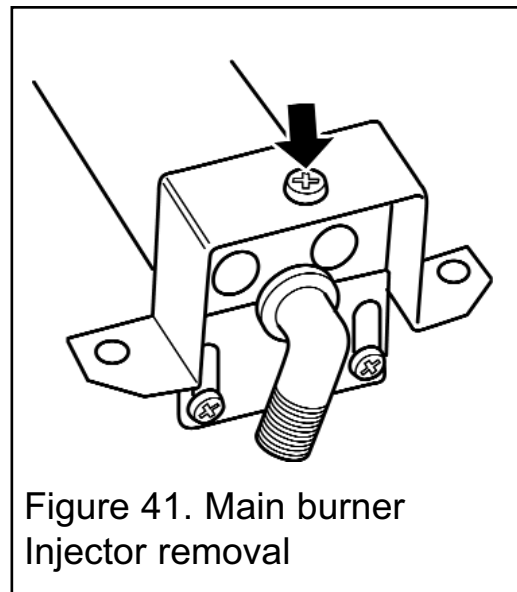

Figure 41. Main burner Injector removal

OWNER GUIDE

OWNER GUIDE

LIST OF CONTENTS

<u>Section</u>	<u>Page</u>
SAFETY	40
GAS CONSUMPTION	41
OPERATING YOUR FIRE	42
The Oxysafe flame sensing & flue blockage safety system.	42
To light the fire	42
To turn the fire off	43
Lighting with a taper	43
CLEANING YOUR FIRE	44
Metal parts.	44
Ceramic fuel effect pieces and burner compartment walls.	44
Burner	44
CERAMIC FUEL BED REFITTING	45
MAINTENANCE	45
Battery replacement	45
Regular maintenance	45
Servicing	46

This gas fire is designed to meet the most stringent quality, performance and safety requirements to provide you with many years' trouble-free service.

This guide aims to improve your understanding and appreciation of your gas fire by providing simple and informative instructions to ensure that you benefit from the excellent performance and features it has to offer.

OWNER GUIDE

SAFETY

IF YOU SMELL GAS

- **DON'T SMOKE.**
- **EXTINGUISH ALL NAKED FLAMES.**
- **DON'T TURN ELECTRICAL SWITCHES ON OR OFF.**
- **TURN OFF THE GAS SUPPLY AT THE METER OR TANK AS APPROPRIATE.**
- **OPEN DOORS AND WINDOWS TO GET RID OF THE GAS.**
- **IMMEDIATELY CALL THE GAS EMERGENCY SERVICE FROM A NEIGHBOURS PHONE - SEE YOUR LOCAL TELEPHONE DIRECTORY.**

Do have the fire installed by a competent person. In the United Kingdom, installation must be in accordance with the latest edition of the Gas Safety (installation & use) Regulations. In the Republic of Ireland, installation must be in accordance with all national and local regulations in force.

Do have the chimney swept prior to installation if it was previously used for solid fuel.

Do have the fire installed in accordance with the installation instructions.

Do allow a minimum clearance of 760 mm from the top of the base of the convector box to the underside of any shelf whether it is made from combustible or non-combustible materials. For a shelf made from wood or other combustible materials deeper than 150mm add 12.5mm to the clearance for every 25mm of additional shelf depth (See figure 1). Please bear this in mind if ever you add a shelf.

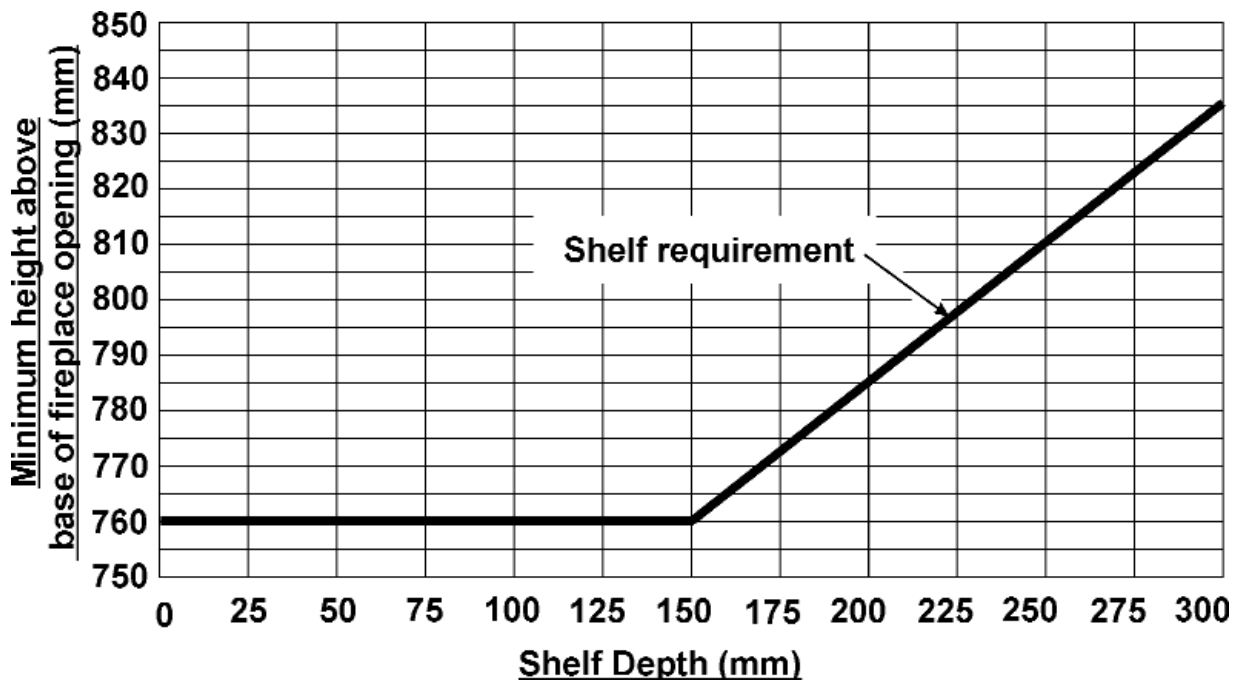

Figure 1. Combustible shelf clearances

OWNER GUIDE

Do provide a suitable guard that complies with BS 8423 for the protection of young children, the elderly, the infirm and pet animals. (Although this fire conforms to all the applicable standards, it is a heating appliance and certain parts of its surface will become hot).

Do wait three minutes before attempting to relight if the fire is switched off or the flames are extinguished for any reason. (Your fire is fitted with a safety device that will automatically shut off the gas supply to the fire if, for any reason, the flames go out).

Do get advice about the suitability of any wall covering near your fire. Soft wall coverings (e.g. embossed vinyl, etc.) which have a raised pattern are easily affected by heat. They may, therefore, scorch or become discoloured when close to a heating appliance. Please bear this in mind whenever you are considering redecorating.

Do provide a minimum side clearance as detailed below:

The minimum mandatory side clearance to combustible surfaces projecting beyond the front of the appliance is 100mm. For access purposes a 10mm clearance to non-combustible surfaces is recommended on the left side of the appliance, on the right side the recommended clearance is 50mm for access to the slider control. Please bear this in mind if ever you are considering altering the room.

Don't hang clothing, towels or any other fabrics over the fire.

Don't add any extra fuel effect pieces above the number stated in the installer and owner guide supplied with the ceramic fuel effect. The installer may have attached it to this guide or placed it inside. Adding extra fuel effect pieces could cause a safety hazard and consequent health hazards.

Don't put paper or any other material on the fire.

Don't place any combustible material (rugs, carpet, plastic tiles, etc.) on the hearth.

Don't attempt to clean or service the fire until it has been switched off and allowed to cool completely.

GAS CONSUMPTION

Model 940

Has a maximum natural gas input of 6.85kW (Gross)

Has a maximum natural gas output of 4.0kW

Has a minimum natural gas input of 2.7kW (Gross)

Has a minimum natural gas output of 1.34kW

Model 940 when converted using kit number 0595211

Has a maximum propane gas input of 6.7kW (Gross)

Has a maximum propane gas output of 3.9kW

Has a minimum propane gas input of 4.3kW (Gross)

Has a minimum propane gas output of 2.29kW

OWNER GUIDE

OPERATING YOUR FIRE

PLEASE NOTE

When operating your fire for the first time, some vapours may be given off which may cause a slight odour and could possibly set off any smoke alarms in the immediate vicinity. These vapours are quite normal with new appliances. They are totally harmless and will disappear after a few hours use.

The Oxysafe flame sensing and flue blockage safety system.

For your safety, this appliance is fitted with a flue blockage safety device which will shut down the appliance in the event of abnormal flue conditions. **This device is NOT a substitute for an independently mounted Carbon Monoxide detector.**

The device will also automatically shut off the gas supply to the fire if the pilot flame goes out due to lack of oxygen or for any other reason.

If this device starts to repeatedly shut off the gas, get expert advice.

This device incorporates a probe which senses that the heat from the pilot flame is correct. If this probe is cool, the device will prevent any gas flow unless the control knob is held in at the ignition position.

If, for any reason, the flames go out when the fire is hot or if the fire is turned off when hot, always **wait at least three minutes before attempting to relight.**

To light the fire.

The slide control is shown in figure 2.

1. Slide the control button to the bottom (ignition) position marked . In this position, the electronic ignition system should cause a series of sparks that should light the pilot. Within four seconds of the pilot igniting, the main burner should light at its minimum setting. If no sparks are produced to light the pilot, the battery may need replacing. Details of battery replacement are given further on in this guide.

Until you can obtain a replacement battery the fire can be lit with a taper as described later in this guide.

2. Keep the button at the ignition position for a further ten seconds. This will prevent the flame-sensing device from shutting off the gas while its probe warms up as explained above.

3. If low heat is required, release the button. The button will automatically spring up to the low heat position shown in figure 2 (See note i below). If for any reason the slider control does not spring up, raise the slider to the off (O) position (Topmost position) and contact your installer. Do not use the fire until the problem has been rectified.

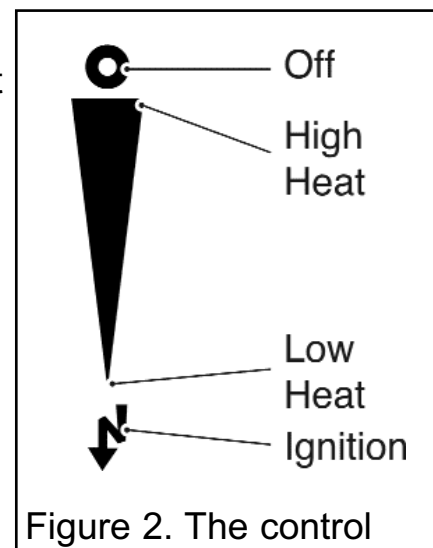

Figure 2. The control

OWNER GUIDE

4. For a higher heat level slide the button upwards. The burner flames and heat output will gradually increase until the button reaches the high heat position shown in figure 2. When the button reaches the high heat position you will feel a check to its movement. **Do not slide the button above the high heat position unless you want to turn the fire off** (See note i below).

- Note**
- i) If the flames go out while setting the control, repeat the full lighting procedure. If the flames repeatedly go out have the fire serviced.
 - ii) Please note. When first turned on the flames will appear predominantly blue. The ceramic fuel effect pieces will take time to warm up. Although some glow will be seen after approximately ten minutes, the full visual effect will only be apparent after a somewhat longer time.
 - iii) The appliance will operate to its maximum potential if the flue is primed during the first 20 – 30 minutes of operation. To do this, simply slide the control button to its highest setting. This will also burn off any carbon deposits that may have formed during previous operations.
 - iv) If operating the appliance for long periods it is beneficial occasionally to change the settings. This will also help to remove any carbon deposits that may form during operation.

To turn the fire off.

1. Slide the button up past the high heat position to the “O” position. Both the main burner and the pilot should go out. While cooling, the ceramic fuel effect pieces may make some crackling noises. This is quite normal.

Lighting with a taper.

(See figure 3).

In the unlikely event of failure of the ignition spark, the pilot can be lit by a taper or long spill. Insert the taper or spill between the second and third left hand ceramic fuel effect pieces on the first row. Operate the slide control as described above.

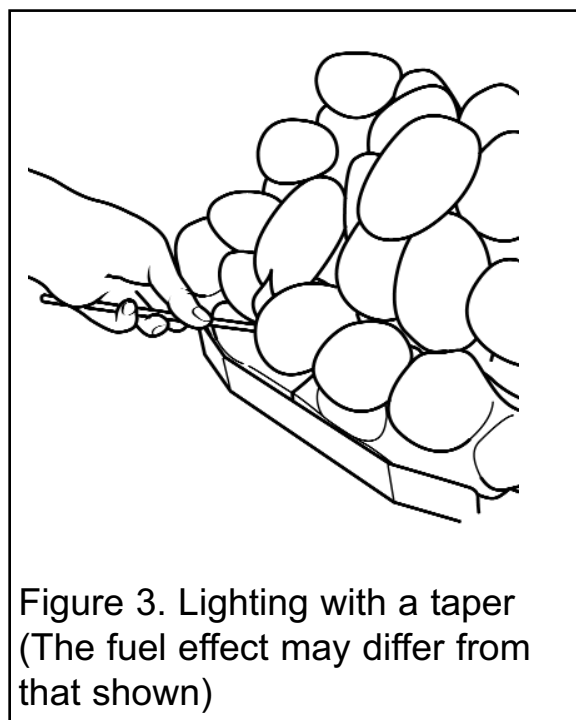

Figure 3. Lighting with a taper
(The fuel effect may differ from that shown)

OWNER GUIDE

CLEANING YOUR FIRE

To maintain the high performance and quality finish of your fire please follow these guidelines:

Before attempting to clean the fire, please remember to turn off the fire and wait for the appliance to cool. The fire will retain heat for some time before cleaning can begin.

If any pieces of debris are found in the firebox, have the chimney inspected before further use.

Metal parts.

- Clean the metal parts with a slightly damp cloth and then dry.
- Do not use abrasive cleaners as these will scratch the fire surface.

Ceramic fuel effect pieces and burner compartment walls.

This product uses fuel effect pieces and burner compartment walls containing Refractory Ceramic Fibres (RCF), which are man-made vitreous silicate fibres. Excessive exposure to this material may cause irritation to eyes, skin and respiratory tract. Consequently, it is important to take care when handling these articles to ensure that the release of dust is kept to a minimum.

- Light coatings of soot will usually be burnt off during the normal operation of the fire. Should any soot accumulation become excessive, the fuel effect pieces and walls should be removed from the fire for cleaning.
- Cleaning should be carried out in a well ventilated area or in the open air by gently brushing with the pieces held away from your face so that you avoid inhaling the dust.
- We do not recommend the use of a normal domestic vacuum cleaner which may blow dust back into the air.
- We suggest that you remove the ceramic fuel effect pieces in the reverse order to that shown in the fuel bed refitting instructions.

Burner.

Remove any deposits of soot or other foreign matter from the surface of the burner with a dry soft brush. Be careful not to brush any particles into the open slots.

Remove any particles from the slots with a vacuum cleaner fitted with a soft brush attachment. **Do not poke wire, etc. into the slots in the burner.**

OWNER GUIDE

CERAMIC FUEL BED REFITTING

The installer and owner guide for the ceramic fuel effect is separate from this guide. The installer may have attached it to this guide or placed it inside. It is important that the installer and owner guide for the ceramic fuel effect is followed correctly. If replacing the ceramic fuel effect, where a new guide is supplied, follow the installer and owner guide supplied with the replacement fuel effect.

Keep the replacement installer and owner guide with this owner guide for future reference.

MAINTENANCE

Battery replacement.

This appliance requires one 9V PP3 Ever Ready Silver Seal (or equivalent) battery.

Fit the new battery firmly to the connections on the ignition block (See figure 4). The +ve and -ve terminal locations are shown on the battery housing.

Regular maintenance.

In order to achieve and maintain high levels of personal safety and performance efficiency, it is essential that the opening at the back of the fire and the flue are kept clear of any form of obstruction. It is possible that deposits of mortar or soot could fall and accumulate causing the flue to be blocked or restricted and so preventing proper clearance of dangerous exhaust fumes.

In the United Kingdom it is the law that a landlord must have any gas appliance, flue and pipework which is situated in a tenant's premises checked for safety at least every twelve months by a competent person (In the UK a GAS SAFE REGISTER engineer, Outside of the UK a CORGI or GAS SAFE REGISTER engineer).

We recommend that all gas appliances and their flues, wherever situated, are checked annually.

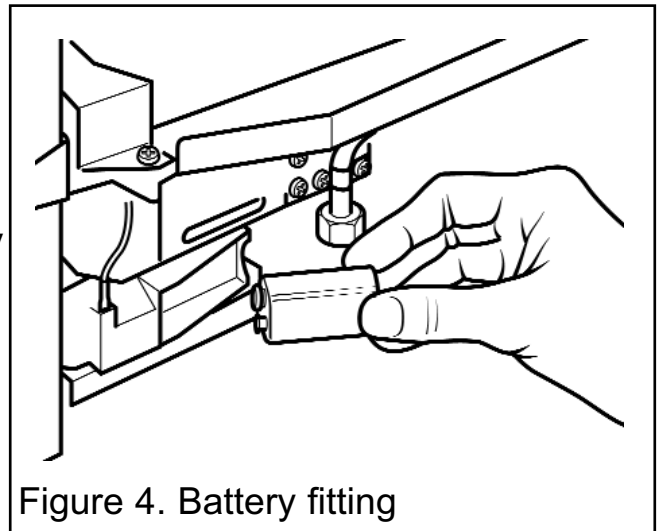

Figure 4. Battery fitting

OWNER GUIDE

Servicing

To help us quickly help you, please try to have the following information available before you contact us:

Type of fire.

Model/Name.

Serial Number.

You will also be asked for the fault, problem or request plus your Post Code.

- If you wish to replace any of the ceramic fuel effect pieces, spare parts are available nationwide via the '**interpart** stockist network'. For your local stockist consult Yellow pages under Central Heating.
- **When fitting replacement parts it is important that only approved parts are used for maximum safety.**

