

INSTALLER AND OWNER GUIDE

Model 955 Heat Engine

INSET LIVE FUEL EFFECT GAS FIRE

This heat engine is designed for use with approved cast fascias and spacer frame / fret combinations.

(GC No. 32-032-76)



For further advice please contact the retailer or company from where you purchased your fire

INSTALLER: Please leave this guide with the owner

THIS APPLIANCE IS FOR USE WITH NATURAL GAS (G20).

**WHEN CONVERTED USING CONVERSION KIT NO. 0595221 THIS APPLIANCE
IS FOR USE WITH PROPANE GAS (G31).**

**THIS APPLIANCE IS SUITABLE ONLY FOR INSTALLATION IN THE UNITED
KINGDOM (GB) AND THE REPUBLIC OF IRELAND (IE).**

© Baxi Heating U.K. Limited 2010.

All rights reserved. No part of this publication may be reproduced in any material form (including photocopying), stored in any medium by electronic means (including in any retrieval system or database) or transmitted, in any form or by any means, whether electronic, mechanical, recording or otherwise, without the prior written permission of the copyright owner.

Applications for the copyright owner's permission to reproduce any part of this publication should be made, giving details of the proposed use, to the following address: The Company Secretary, Baxi Heating UK Limited, The Wyvern Business Park, Stanier Way, Derby, DE21 6BF.

Warning: Any person who does any unauthorised act in relation to a copyright work may be liable to criminal prosecution and civil claims for damages.

Because our policy is one of constant development and improvement, details may vary slightly from those given in this publication

Safety First.

This fire is CE Approved and designed to meet the appropriate British Standards and Safety Marks.



Quality and Excellence.

This fire has been manufactured to the highest standards of quality and excellence and are manufactured under a BS EN ISO 9001 quality system accepted by the British Standards Institute.



The Highest Standards

The manufacturer is a member of SBGI and HHIC (Heating and Hot water Industry Council) that work to ensure high standards of safety, quality and performance.



Careful Installation

This gas fires must be installed by a competent GAS SAFE REGISTER engineer (GAS SAFE REGISTER or CORGI engineer outside of UK) in accordance with our installer guide and should not be fitted directly on to a carpet or floor of combustible material.



INSTALLER GUIDE

FOR OWNER GUIDE SEE PAGES 34 TO 41

INSTALLER GUIDE

CONTENTS

<u>Section</u>	<u>Heading</u>	<u>Page</u>
	INSTALLER GUIDE	4 - 33
	OWNER GUIDE	34 - 41
1.	SAFETY AND UNPACKING	7
2.	APPLIANCE DATA AND EFFICIENCY	8
	2.1 General information.	8
	2.2 Efficiency.	8
3.	GENERAL INSTALLATION REQUIREMENTS	9
	3.1 Regulations, Standards and Law.	9
	3.2 Ventilation requirements.	10
	3.3 The Atmosphere sensing device (ASD).	10
	3.4 Fireguard requirements.	10
	3.5 Room considerations.	10
	3.6 Chimney preparation.	10
	3.7 Fireplace preparation.	11
	3.8 The hearth.	11
	3.9 Fireplace clearances.	12
	3.10 Installation options.	12
	3.10.1 Conventional fireplace and hearth.	12
	3.10.1.1 'Hole-in-the-wall' installations	13
	3.10.2 Metal flue box and hearth.	14
	3.10.3 Precast concrete or clay flue block system and hearth.	14
	3.11 Flues.	15
	3.12 Propane gas fires.	16
4.	PACK CONTENTS	16
5.	FIREPLACE CHECK	18
	5.1 Soundness for appliance attachment.	18
	5.2 Fireplace flue pull.	18
6.	IGNITION CHECK	19
7.	GAS SUPPLY CONNECTION	19
8.	PREPARING APPLIANCE FOR INSTALLATION	20
	8.1 Appliance preparation.	20
	8.2 Fitting the foam seal.	20
	8.3 The flue restrictor.	21
9.	CONVECTION BOX INSTALLATION	21
	9.1 Method 1 - Front fixing to fireplace surround.	21
	9.2 Method 2 - Cable retention.	22
	9.3 Floor sealing.	23

Continued on next page

INSTALLER GUIDE

CONTENTS (Continued)

<u>Section</u>	<u>Heading</u>	<u>Page</u>
10.	BURNER INSTALLATION	24
10.1	Burner and supply pipe installation.	24
10.2	Preliminary burner checks.	24
10.3	Inlet pressure check.	25
10.4	Fitting the burner tray trim.	25
11.	FITTING THE CERAMIC FUEL EFFECT	25
12.	FITTING THE FASCIA	25
13.	FULL OPERATING CHECKS	26
13.1	Check the control settings.	26
13.1.1	Lighting the burner.	26
13.1.2	Operating the burner.	26
14.	SPILLAGE AND FLAME SUPERVISION CHECKS	27
14.1	Check for spillage.	27
14.2	Flame supervision and spillage monitoring system.	28
15.	FINAL REVIEW	29
16.	SERVICING & PARTS REPLACEMENT	30
16.1	Checking the aeration setting of the burner.	31
16.2	To remove the fascia.	31
16.3	To remove the burner unit.	31
16.4	To remove the pilot unit.	31
16.5	To remove the gas valve.	32
16.6	To replace the burner.	32
16.7	To remove the main burner injector.	33
16.8	To remove the appliance from the fireplace.	33

INSTALLER GUIDE

1. SAFETY AND UNPACKING

Installer

Before continuing any further with the installation of this appliance please read the following guide to manual handling.

- The approximate lifting weight of this heat engine and convection box is 7.4 kg.
- One person should be sufficient to lift the heat engine and convection box. If for any reason this weight is considered too heavy then obtain assistance.
- When lifting always keep your back straight. Bend your legs and not your back.
- Avoid twisting at the waist. It is better to reposition your feet.
- Avoid upper body/top heavy bending. Do not lean forward or sideways whilst handling the fire.
- Always grip with the palm of the hand. Do not use the tips of fingers for support.
- Always keep the fire as close to the body as possible. This will minimise the cantilever action.
- Use gloves to provide additional grip.
- Always use assistance if required.

This product uses fuel effect pieces and a burner compartment rear wall containing Refractory Ceramic Fibres (RCF), which are man-made vitreous silicate fibres. Excessive exposure to these materials may cause irritation to eyes, skin and respiratory tract. Consequently, it is important to take care when handling these articles to ensure that the release of dust is kept to a minimum. To ensure that the release of fibres from these RCF articles is kept to a minimum, during installation and servicing we recommend that you use a HEPA filtered vacuum to remove any dust and soot accumulated in and around the fire before and after working on the fire. When replacing these articles we recommend that the replaced items are not broken up, but are sealed within a heavy duty polythene bag, clearly labelled as RCF waste. RCF waste is classed as a stable, non-reactive hazardous waste and may be disposed at a landfill licenced to accept such waste. Protective clothing is not required when handling these articles, but we recommend the use of suitable gloves to prevent irritation. We also recommend you follow the normal hygiene rules of not smoking, eating or drinking in the work area and always wash your hands before eating or drinking.

This appliance does not contain any component manufactured from asbestos or asbestos related products.

INSTALLER GUIDE

2. APPLIANCE DATA AND EFFICIENCY

2.1 General information.

Gas	Natural (G20)	Propane (G31) *
Inlet Pressure	20mbar	37mbar
Input - Max. (Gross)	6.0kW (20,500 Btu/h)	6.1kW (20,800 Btu/h)
Input - Min. (Gross)	2.3kW (7,8502 Btu/h)	3.8kW (12,965 Btu/h)
Inlet Test Pressure (Cold)	20.0 ± 1.0 mbar (8.0 ± 0.4 in w.g.)	37.0 ± 1.0 mbar (14.85 ± 0.4 in w.g.)
Gas Connection	8mm pipe	8mm pipe
Burner Injector	Cat 82 - 069	Size 128
Pilot & Atmosphere Sensing Device	Copreci Ref. O.D.S 21500/166	Copreci Ref. O.D.S 21500/166 Fitted with RBM 180 - 02 injector
Ignition	Piezo Electric. Integral with Gas Tap	Piezo Electric. Integral with Gas Tap
Aeration	Factory set	Non-adjustable

* When converted using Kit 0595221

The appliance information label is located on a plate at the base of the fire. This can be seen by removing firefront / firefront casting.

2.2 Efficiency.

The efficiency of this appliance has been measured as specified in BS 7977 - 1 and the result is as below:

<u>Model</u>	<u>Efficiency % (Gross)</u>
955	55
955 when converted to LPG.	58

The gross calorific value of the fuel has been used for this efficiency calculation. The test data from which it has been calculated has been certified by Advantica Certification services (0087). The efficiency value may be used in the UK Government's Standard Assessment Procedure (SAP) for energy rating of dwellings.

The conversion of **net** efficiency to **gross** was achieved by multiplying the net efficiency by the following conversion factor from Table E3 of SAP 2005, rounding down to the nearest whole number.

INSTALLER GUIDE

Gas	Conversion factor from net to gross efficiency
Natural Gas	0.901
LPG	0.921

3. GENERAL INSTALLATION REQUIREMENTS

3.1 Regulations, Standards and Law.

The installation must be in accordance with these instructions.

For the user's protection, in the United Kingdom it is the law that all gas appliances are installed by competent persons in accordance with the current edition of the Gas Safety (Installation and Use) Regulations. Failure to install the appliance correctly could lead to prosecution. GAS SAFE REGISTER and CORGI require their members to work to recognised standards.

In the United Kingdom the installation must also be in accordance with:

All the relevant parts of local regulations.

All relevant codes of practice.

The relevant parts of the current editions of the following British Standards:-

BS EN 1856 Part 1 - Chimneys - Requirements for metal chimneys.

BS 715 - Specification for metal flue boxes for gas-fired appliances not exceeding 20kW.

BS EN 1858 - Chimneys - Components - Concrete flue blocks.

BS EN 1806 - Chimneys - Clay / ceramic flue blocks.

BS EN 1856 Part 1 - Chimneys - Requirements for metal chimneys.

BS 5440 Part 1 - Installation of flues.

BS 5440 Part 2 - Installation and maintenance of flues and ventilation for gas appliances of rated input not exceeding 70 kW net (1st, 2nd and 3rd family gases).

BS 6461 Part 1 - Masonry chimney & flues - Installation

BS 1251 - Fireplace components

BS 5871 Part 2 - Installation - Inset LFE gas fires

BS 6891 - Gas pipework installation

- In England and Wales, the current edition of the Building Regulations issued by the Department of the Environment and the Welsh Office.
- In Scotland, the current edition of the Building Standards (Scotland) Regulations issued by the Scottish Executive.
- In Northern Ireland, the current edition of the Building regulations (Northern Ireland) issued by the Department of the Environment for Northern Ireland.

Where no specific instructions are given, reference should be made to the relevant British Standard Code of Practice.

INSTALLER GUIDE

3.2 Ventilation requirements.

Normal adventitious ventilation is usually sufficient to satisfy the ventilation requirements of this appliance. In GB reference should be made to BS 5871 Part 2 and in IE reference should be made to the current edition of IS 813 "Domestic Gas Installations" which makes clear the conditions that must be met to demonstrate that sufficient ventilation is available.

3.3 The Atmosphere sensing device (ASD).

The appliance is fitted with an A.S.D (Atmosphere sensing device). If the appliance closes down after a period of operation for no apparent reason, the consumer should be informed to stop using the appliance until the installation and appliance have been thoroughly checked. The A.S.D will shut the appliance down if an unacceptable amount of harmful products of combustion accumulate. Under no circumstances should the A.S.D be altered or bypassed in any way. Only a genuine manufacturer's replacement part should be fitted. The individual A.S.D components are not replaceable.

3.4 Fireguard requirements.

A fireguard complying with BS 8423 should be fitted for the protection of young children, the elderly, the infirm and pet animals.

3.5 Room considerations.

3.5.1 This appliance must not be installed in any room that contains a bath or shower or where steam is regularly present.

3.5.2 An extractor fan may only be used in the same room as this appliance, or in any area from which ventilation for the appliance is taken, if it does not affect the safe performance of the appliance. Note the spillage test requirements detailed further on in this manual. If the fan is likely to affect the appliance, the appliance must not be installed unless the fan is permanently disconnected.

3.5.3 Note that soft wall coverings (e.g. embossed vinyl, etc.) are easily affected by heat. They may scorch or become discoloured when close to a heating appliance. Please bear this in mind when installing.

3.6 Chimney preparation.

3.6.1 If the appliance is intended to be installed to a chimney that was previously used for solid fuel, the flue must be swept clean prior to installation. All flues should be inspected for soundness and freedom from blockages.

3.6.2 Any chimney damper or restrictor should be removed. If removal is not possible, they must be secured in the open position.

INSTALLER GUIDE

3.7 Fireplace preparation.

3.7.1 If the fireplace opening is an underfloor draught type, it must be sealed to stop any draughts.

3.7.2 The fireplace floor should be reasonably flat to ensure that the convection box can be installed without it rocking and so that a good seal can be made at the bottom front of the box.

3.7.3 The front face of the fireplace should be reasonably flat over the area covered by the convection box top and side flange seals to ensure good sealing. These faces should be made good if necessary.

3.7.4 If the appliance is to be fitted against a wall with combustible cladding, the cladding must be removed from the area covered by the fascia. The cladding must also not touch the fascia (See figure 1). We suggest that the actual fascia is used as a template to mark the area for combustible cladding removal and that this area is increased by at least 2mm all round.

3.7.5 If the fireplace opening is greater than the acceptable dimensions given in this guide, do not use the back of a fire surround or marble to reduce the opening. This may cause cracking of the surround back or marble.

3.8 The hearth.

The appliance must be mounted behind a non-combustible hearth (N.B. conglomerate marble hearths are considered as non-combustible). The appliance can be fitted to a purpose made proprietary class "O"-150°C surround. The hearth material must be at least 12mm thick. The periphery of the hearth (or fender) should be at least 50mm above floor level to discourage the placing of carpets or rugs over it.

The appliance must not stand on combustible materials or carpets (See figure 3).

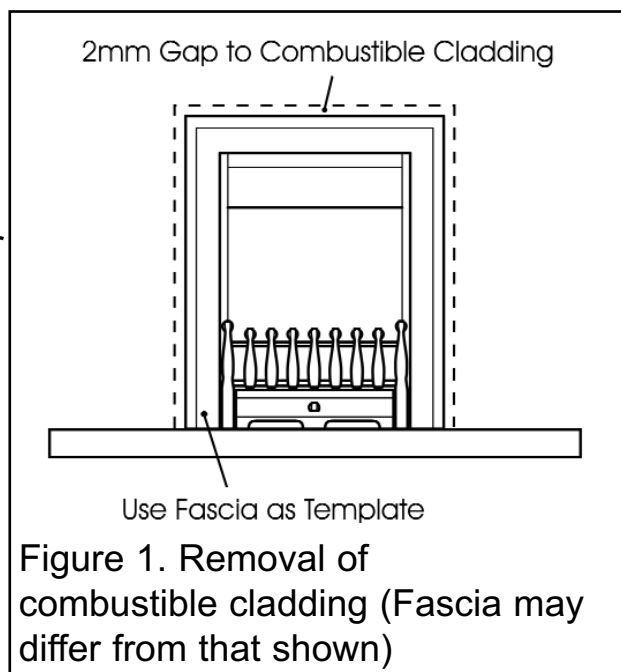

Figure 1. Removal of combustible cladding (Fascia may differ from that shown)

INSTALLER GUIDE

3.9 Fireplace clearances.

3.9.1 The minimum height from the top surface of the hearth to the underside of any shelf made from wood or other combustible materials is detailed below.

- For a shelf up to 150mm deep: Minimum height = 750mm.
- For a shelf deeper than 150mm: 750mm + 12.5mm for every 25mm depth over 150mm (See Figure 2).

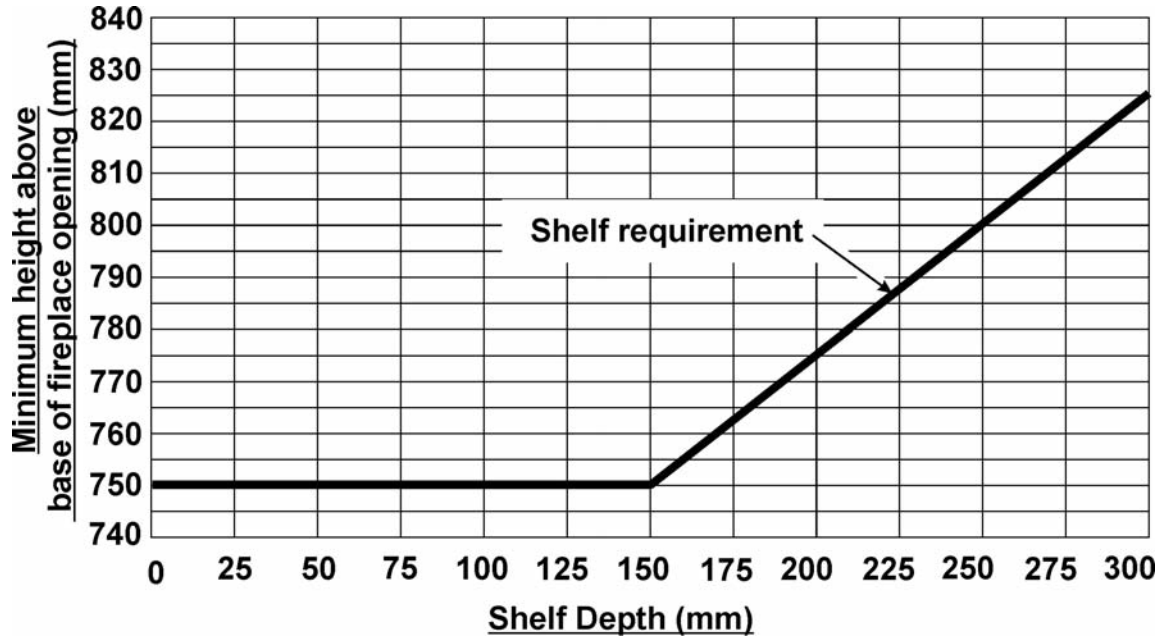

Figure 2. Combustible shelf clearances

3.9.2 The minimum allowable distance from the outside of the fascia to a corner wall having combustible material or any other combustible surface which projects beyond the front of the appliance is 100mm.

For access purposes a 10mm clearance to non-combustible surfaces is recommended on the left side of the appliance, on the right side the recommended clearance is 50mm for access to the slider control.

3.10 Installation options.

In the United Kingdom, as supplied, the appliance can be installed in the following situations: -

3.10.1 Conventional fireplace and hearth.

To a fireplace complete with hearth as shown in figure 3. Chair brick removal may not be required providing at least 50mm clearance is available from the flue outlet to any fireplace component.

INSTALLER GUIDE

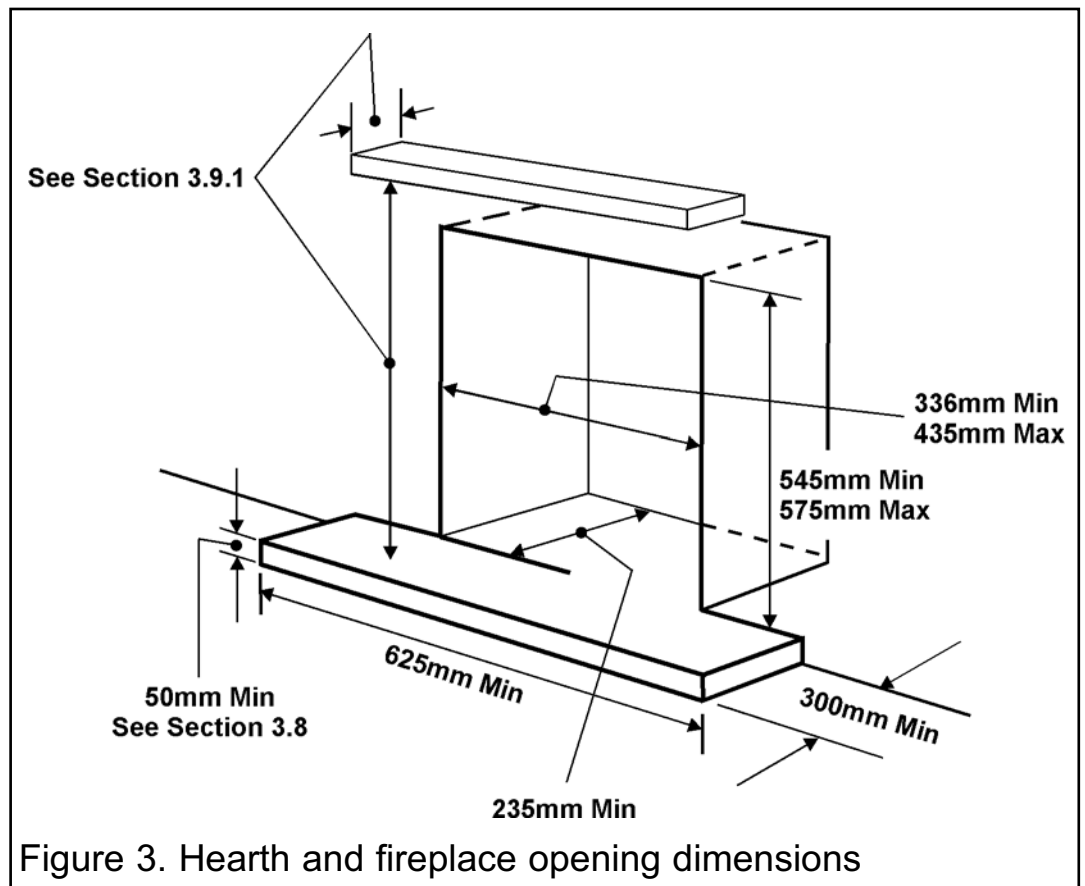

3.10.1.1 'Hole-in-the-wall' installations

- It is recommended that a hearth should be installed as in section 3.8 (See figure 3).
- If fitting a fascia that has a firefront designed to sit on a hearth, a reduced depth hearth is recommended. The recommended reduced hearth depth is 100mm, this is necessary to support the firefront. The heat engine must be installed so that distance from the base of the fireplace opening in the wall to the finished floor level shall be at least 72mm. Where there is no floor covering or carpet, and the floor is of a type that is likely to be covered in such a way, then the distance from the base of the fireplace opening in the wall to the finished floor level should be increased to at least 147mm.
- If fitting a fascia that does not have a separate firefront and a hearth is not fitted, the heat engine must be installed so that distance from the base of the fireplace opening in the wall to the finished floor level shall be at least 72mm. Where there is no floor covering or carpet, and the floor is of a type that is likely to be covered in such a way, then the distance from the base of the fireplace opening in the wall to the finished floor level should be increased to at least 147mm.
- To protect from the risk of burns and ignition of clothing a tactile separator shall be used. The hearth detailed in section 3.9 meets the requirements for a tactile separator. If this is not used then a 625mm long fender, kerb, horizontal bar, or

INSTALLER GUIDE

other barrier, being fixed not less than 50mm above floor level and positioned 300mm in front of the fixing plane of the fire will meet the requirement.

3.10.2 Metal flue box and hearth.

The appliance can be installed to a fireplace incorporating a metal flue box complying with the constructional requirements of the current edition of BS 715 and with a flue conforming to BS EN 1856 part 1. The dimensions of the flue box must conform to those shown in figure 4.

The top surface of the metal flue box must be covered with a 50mm layer of mineral wool or equivalent insulation (See figure 4).

Important Note: Where the flue box has a base sheet that is single wall (i.e. a single metal sheet) the flue box must be mounted on a non-combustible hearth. The hearth material must be at least 12mm thick.

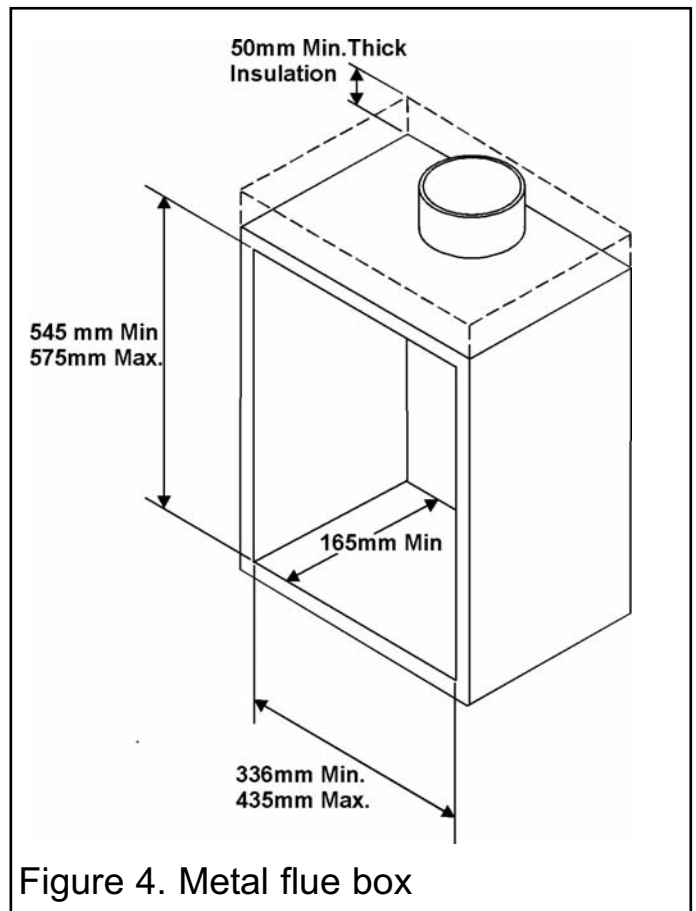

3.10.3 Precast concrete or clay flue block system and hearth.

The appliance can be installed to a precast concrete or clay flue block system conforming to BS1289 or BS EN 1858 with dimensions as in figure 5.

BS 1289 part 1 recommends there should be an air space or insulation between the flue blocks and the plaster because heat transfer may cause cracking on directly plastered flues. However, generally this appliance is suitable for installations under all circumstances unless there is a history of cracking problems. Remember that faults such as cracking may be caused by poorly built and restrictive flues, e.g. mortar extrusions, too many bends, flue heights below three metres, restrictive terminations etc.

The appliance is suitable for installations conforming to older versions of BS1289 as well as the current edition. The flue blocks must have a minimum width not less than 63mm and a cross-sectional area not less than 13,000mm². Older editions of BS1289 required a cross-sectional area of 13,000mm². The current revision of the standard requires 16,500mm². This appliance is suitable in both cases. The total depth of the opening measured from the finished front of the fireplace (Including plaster, surround etc.) must be as below:

INSTALLER GUIDE

- If the width at the rear of the precast flue starter blocks is 300mm or greater the depth of the opening is to be not less than 138mm. Under these conditions the eyebolts will need to be located as close to the sides of the starter blocks as possible.
- If the width at the rear of the precast flue starter blocks is less than 300mm then an additional 16mm of depth will be required to accommodate the eye bolts. Therefore if the starter blocks are less than 300mm wide the minimum depth of the opening will be not less than 154mm.

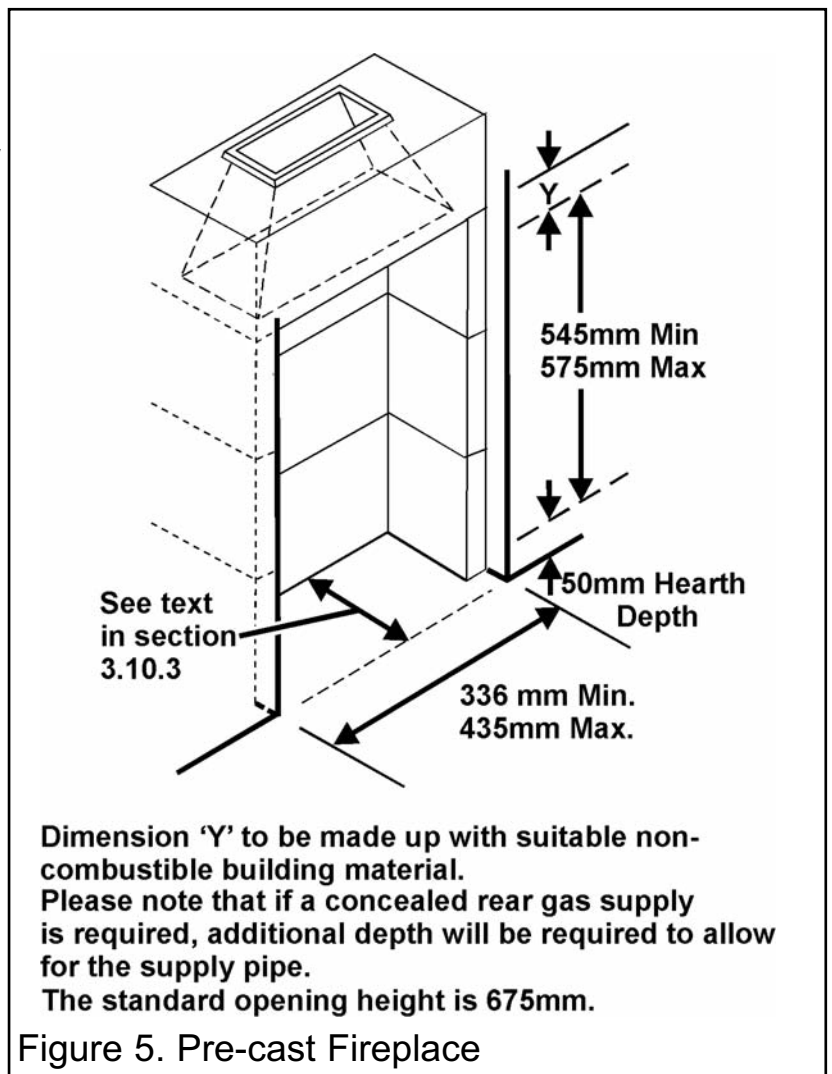

3.11 Flues.

1. Suitable flues and minimum flue sizes are as follows:

It should be noted that, as with many appliances, sharp bends or horizontal runs in metal flues at the top of the system can be a cause of problems in these types of installation.

- 225mm x 225mm conventional brick flue.
- Single wall, twin wall or flexible flue liner with a minimum diameter of 125mm. The materials to be used are stainless steel or aluminium as specified in BS EN 1856 Part 1. The liner must be sealed to the surrounding area above the fireplace opening and to the top of the chimney. An approved terminal must be fitted.
- 175mm diameter lined brick or stone flue.
- 200mm diameter factory made insulated flue manufactured to BS4543 Part 2.
- 175mm diameter flue pipe. See BS6461 Part 1 for suitable materials.
- A properly constructed precast concrete or clay flue system conforming to BS1289 or BS EN 1858. This system is only suitable if the conditions stated in section 3.10.3 are met.

2. The flue must conform to BS 5440: Part 1 in design and installation.

The flue, measured from the bottom of the fireplace opening to the bottom of the terminal, shall be not less than 3m in actual vertical height. When calculated in

INSTALLER GUIDE

accordance with BS 5440: Part 1 Annex A, the minimum **equivalent** height of the flue shall be 2.0m of 125mm dia. flue pipe.

3. The flue must not be used for any other appliance or application.

4. Proprietary terminals must comply with BS 715 or BS 1289. Any terminal or termination must be positioned in accordance with BS 5440 Part 1 to ensure that the products of combustion can be safely dispersed into the outside atmosphere. Where the appliance is connected to an unlined brick chimney it is generally unnecessary for the chimney pot to be replaced or for a terminal to be fitted unless the flue has a diameter smaller than 170mm.

5. The flue must be completely sealed so that combustion products do not come into contact with combustible materials outside the chimney.

3.12 Propane gas fires.

Propane gas appliances must not be installed in a room, which is built entirely below ground level (See BS 5871 Pt2).

4. PACK CONTENTS

The items required for this appliance are packed in three sections.

Section 1 - Fire unit contains:

- 1 Convection box and burner assembly.
- 1 Loose parts pack including: -
 - 1 Grommet for rear of convection box.
 - 1 Nut and olive for 8mm inlet pipe.
 - 1 Strip of floor sealing tape.
 - 1 Flue restrictor
- 3 No.8 x 3/8" screws for securing the restrictor.
- 4 Fibre / wooden plugs.
- 4 Woodscrews.
- 2 Tension cables.
- 2 Cable adjusters.
- 2 Eyebolts.
- 1 Length of self-adhesive foam seal.
- 1 Inlet "T" connector including pressure test point.
- 1 Burner tray trim.
- 1 Ceramic fuel effect (Not shown)
- 2 No.8 x 3/8" screws for securing the fascia.

INSTALLER GUIDE

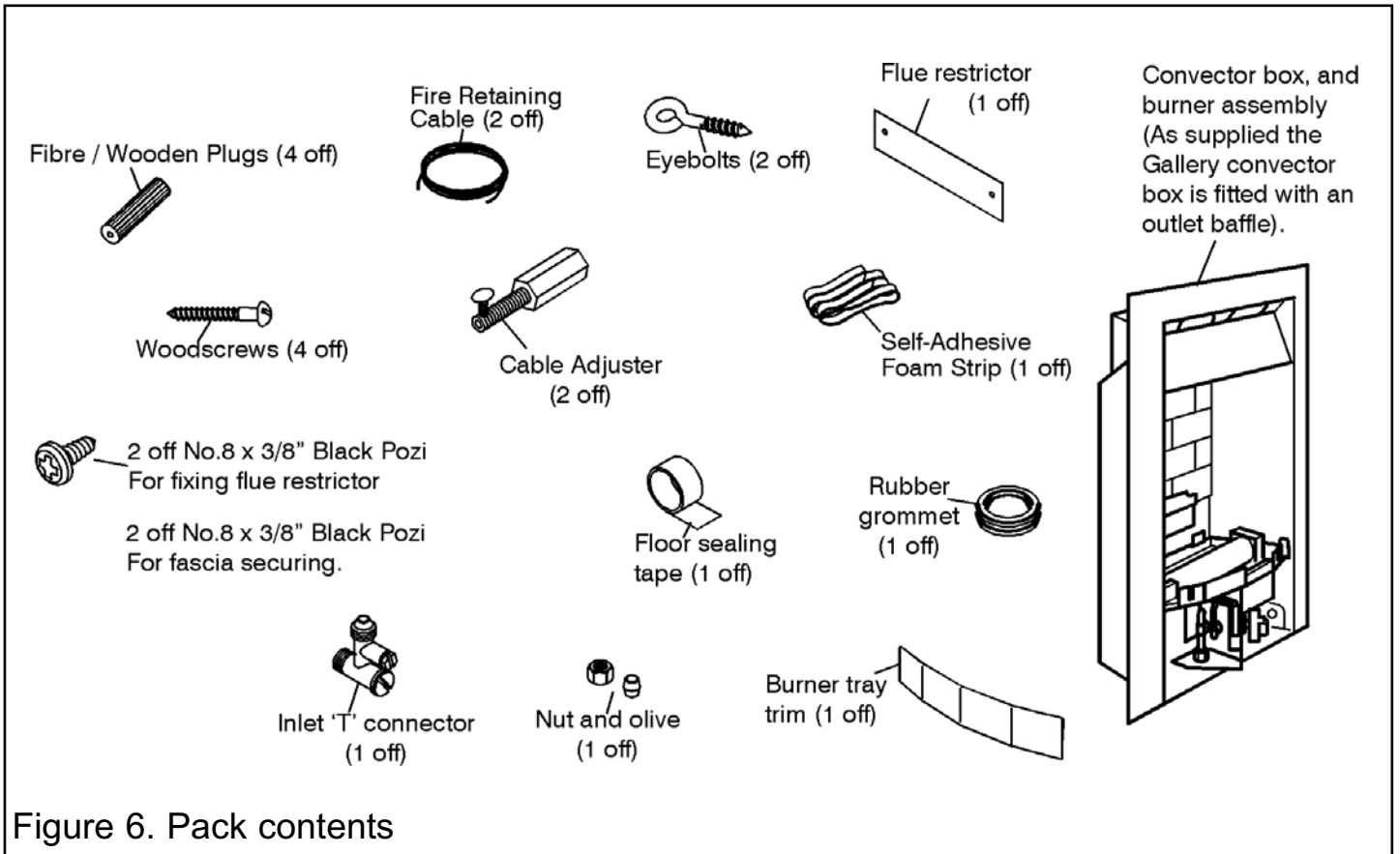

Figure 6. Pack contents

Remove all the items carefully to prevent damage. Take special care when handling the ceramic components. Some items may be contained in the packaging fittings - Examine the packaging carefully before discarding. Check that all the items are present and undamaged.

5.1 Soundness for appliance attachment.

Two primary methods of retaining the appliance are provided: -

- 1) By fixing to the fireplace front surround.
- 2) Using concealed tension cables fixed to the rear of the fireplace opening together with secondary fixing to the fireplace floor.

The methods are detailed in section 9 of this manual. Before selecting the retention method, consult with the customer. Method 2 is provided for instances where drilling holes in the front surface of the fireplace surround is unacceptable to the customer or otherwise impractical. *N.B. It is unwise to attempt to drill into marble without the proper tools and equipment.*

If method 1 is chosen, make sure that the front surround area is sound enough to take the fibre / wooden plugs and woodscrews. If necessary, make sound with suitable cement.

If method 2 is chosen, make sure that the area at the back is sound enough to take the eyebolts. If these areas have deteriorated due to prolonged use, they should be made sound with suitable cement.

5.2 Fireplace flue pull.

Close all doors and windows in the room in which the appliance is to be installed.

After confirming with a match that smoke is drawn into the flue, light a 13 gram smoke pellet and check that there is a definite flow through the flue. Verify outside that the smoke exits from one terminal only and that the termination is suitable.

Observe where possible, upstairs rooms and loft spaces for signs of escaping smoke indicating a defective flue. If there is not a definite flow warm the flue for a few minutes and repeat the smoke pellet test. If there is still no definite flow the flue may need remedial work – **Do not fit the appliance until there is a definite flow through the flue.**

INSTALLER GUIDE

6. IGNITION CHECK

Before attempting to install, it is worth checking that the ignition system performs satisfactorily.

- Set the control knob to the 'OFF' position.
- Depress the control knob and rotate it anticlockwise to the 'pilot ignition' position. A 'click' will be heard as the integral piezo operates. A spark should be seen between the electrode and pilot tip. If there is no spark check the following: -
 - Ensure that the electrode lead is connected to the terminal at the base of the electrode.
 - If the above is correct, check for damage to the electrode lead.

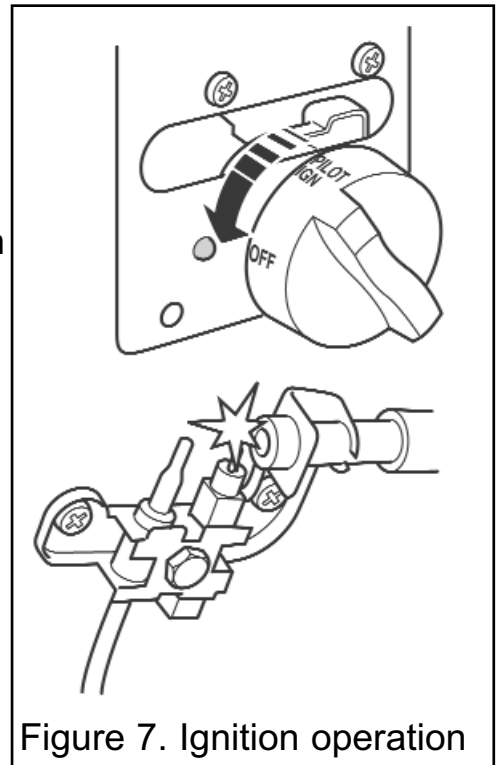

Figure 7. Ignition operation

7. GAS SUPPLY CONNECTION

A nut and olive are provided for an 8mm pipe inlet connection to the inlet 'T' connector at the bottom front of the appliance. The inlet 'T' connector can be rotated to allow a connection from any direction. The inlet 'T' connector includes a valve for isolating the gas supply and a pressure test point.

The supply pipe must be rigid material. Flexible pipe must not be used.

Concealed supply pipe connection.

If a concealed connection from inside the fireplace is required then, **before the appliance is fitted into the fireplace** it will be necessary to extend the supply line so that it will project through the hole in the back of the convection box and run to the inlet 'T' connector at the front. The pipe run from the supply line up to the rear opening in the convection box must be kept away from the area which will be taken by the convection box when it is installed. Note that the centre of the appliance inlet 'T' connector is 25mm above the fireplace floor. The inlet 'T' connector should be fitted to the supply pipe at this stage.

INSTALLER GUIDE

8. PREPARING APPLIANCE FOR INSTALLATION

8.1 Appliance preparation.

1. Remove any transit tape and packing and inspect for any evidence of mishandling which might affect the performance. Each unit is flame tested before it leaves the factory and as a result there may be slight discolouration around the burner ports.
2. Detach the burner unit from the convection box by removing two screws (See figure 8). Lift the burner unit clear.
3. **It is important that the grommet supplied in the loose parts pack is fitted to the hole in the rear of the convection box.**

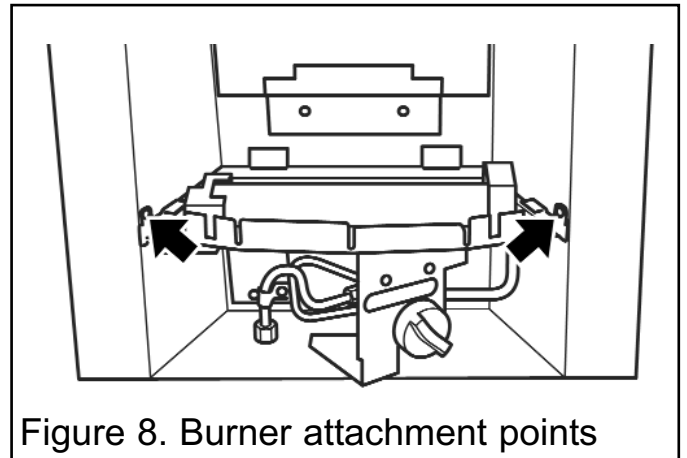

Figure 8. Burner attachment points

8.2 Fitting the foam seal.

1. **For models with fascias that are located to the front of the convection box flanges:** There is a length of self adhesive foam seal supplied with the fire. This will need to be fitted to the outer rear edges of the side and top flanges of the convection box. Cut the foam seal to the required length. Be careful not to stretch the seal when measuring. Remove the protective backing from the foam seal and fit this to the rear of the convection box flange (See figure 9).
2. **For models with fascias that slide onto the convection box flanges:**

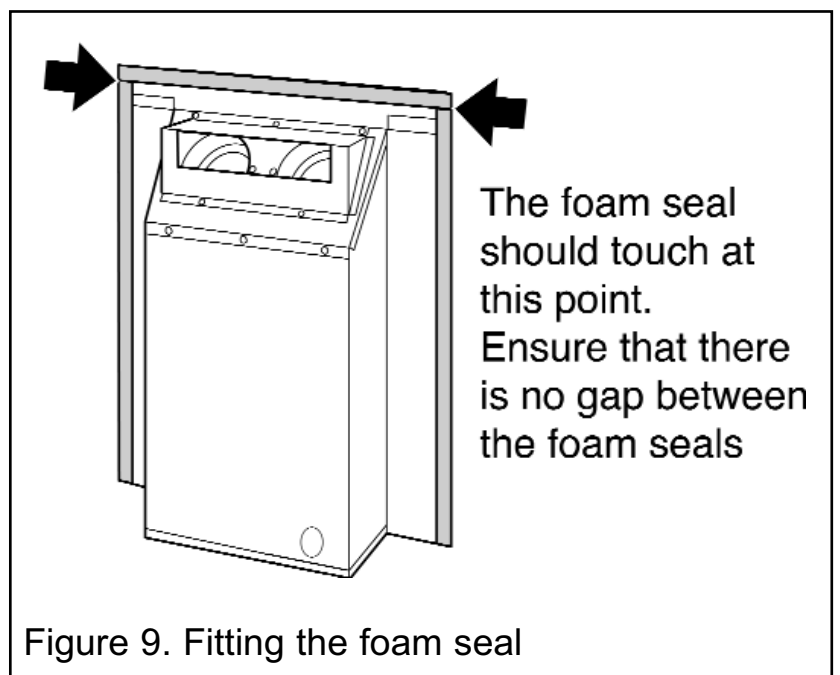

Figure 9. Fitting the foam seal

There is a length of self adhesive foam seal supplied with the fire. This will need to be fitted to the outer rear edges of the side and top flanges of the convection box. This will be fitted over the flanges of the fascia. **It is therefore important to ensure that the fascia is positioned correctly before fitting the foam seal.** (See fascia fitting guide supplied with the fascia). Cut the foam seal to the required length. Be careful not to stretch the seal when measuring. Remove the protective backing from the foam seal and fit this to the rear of the convection box flange (See figure 9).

INSTALLER GUIDE

8.3 The flue restrictor.

This appliance is supplied with a flue restrictor for use where the flue draught is excessive. **The restrictor must not be fitted where a precast flue or a 125mm flue liner is used.** For flue liners greater than 125mm and all other installations the restrictor should be fitted. There may however, be certain exceptional circumstances where fitting the restrictor causes the fire to fail the spillage test. In such cases the restrictor will have to be removed. After removal conduct the spillage check again.

Fit the restrictor as shown in figure 10 using the two screws provided.

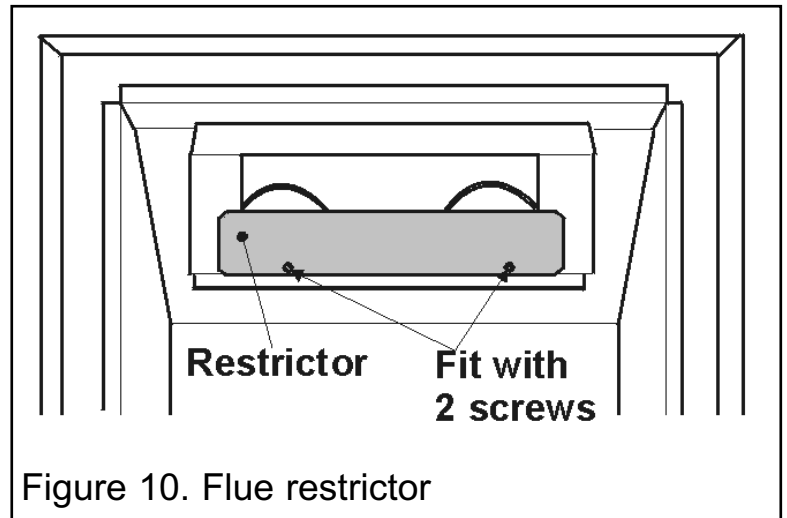

Figure 10. Flue restrictor

9. CONVECTION BOX INSTALLATION

9.1 Method 1 - Front fixing to fireplace surround.

(This method of fixing may not be suitable for fires with fascias that slide onto the convection box flanges. The screw heads may prevent fascia fitting).

1. Make sure that the fireplace front surround area is sound enough to take the fibre / wooden plugs and woodscrews. If necessary, make sound with suitable cement.
2. Place the convection box centrally in the fireplace in the position in which it is to be permanently installed. If a concealed connection is being used, insert the convection box into the fireplace feeding the supply pipe through the pierced hole in the grommet.
3. Mark the fireplace front surround through the four fixing holes in the side flanges of the convection (See figure 11).
4. Remove the convection. Drill four holes in the fireplace front surround at the marked positions using a suitably sized drill bit for the fibre / wooden plugs supplied.
5. Insert a fibre / wooden plug into each hole.
6. Place the convection box back in position in the fireplace.
7. Fit a woodscrew through each hole in the convection box flanges and tighten to seal the box to the fireplace surround.

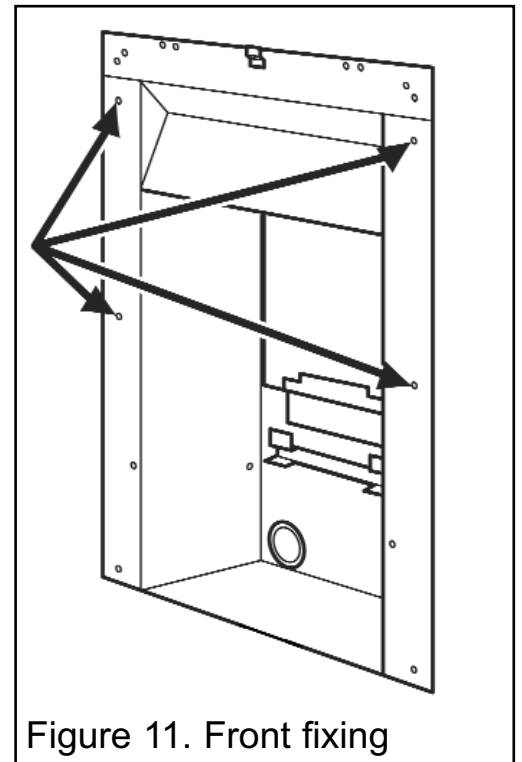

Figure 11. Front fixing

INSTALLER GUIDE

9.2 Method 2 - Cable retention.

1. Make sure that the relevant areas at the fireplace back are sound enough to take the eyebolts. If these areas have deteriorated due to prolonged use they should be made sound with suitable cement.

2. Drill two holes in the rear wall of the fireplace for the eyebolt plugs. The holes should be drilled within the range of positions shown in figure 12 using a suitably sized masonry drill bit for the fibre / wooden plugs supplied. The holes should be equidistant each side of the centre line of the fireplace to ensure that the appliance finishes centrally in the opening when tension is applied to the cables.

3. Insert a fibre / wooden plug into each hole. Use the fibre / wooden plugs supplied with this appliance - **Never use plastic plugs instead of the fibre / wooden plugs supplied.** Screw the eyebolts into the plugs. Make sure that the bolts are secure.

4. Place the convection box unit close to the fireplace but allow sufficient access into the fireplace opening so that the cables can be threaded through the eyebolts and returned through the back of the convection box.

If a concealed connection is being used, insert the convection box into the fireplace feeding the supply pipe through the pierced hole in the rear seal.

5. The rear of the convection box has a slot and hole each side of the outlet opening. Assemble one end of the cable to the top of the fire by passing it through the small round hole and locking by positioning the cable in the adjacent slot (See figure 13). Give the cables a pull so that they grip.

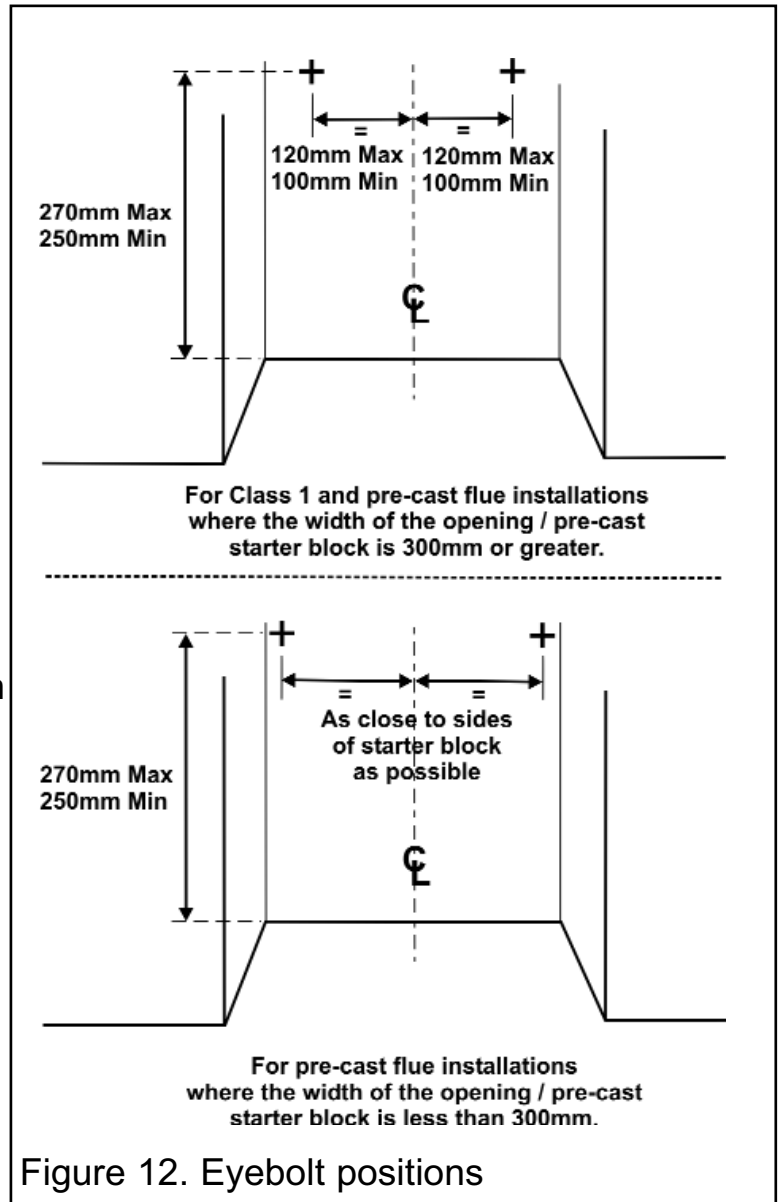

Figure 12. Eyebolt positions

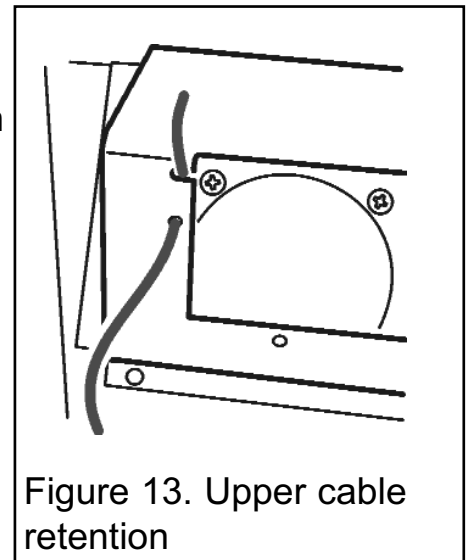

Figure 13. Upper cable retention

INSTALLER GUIDE

6. Thread the cables through the eyebolts in the rear wall. Return the cables through the holes near the bottom corners of the convection box back panel (See figure 14).

7. Place the convection box fully back into the fireplace opening so that it is sealed against the fireplace front surround.

8. Fit a cable retainer over the bottom end of each cable.

9. Pull each cable taut. Push the cable retainers hard up against the back panel. Tighten the screws in the retainers so that they clamp the cables in position. Apply tension to the cables by turning the hexagonal adjusters by hand (See figure 15).

10. Inspect the installation of the convection box against the fireplace surround. If the convection box is aligned squarely and the sealing is satisfactory, fully tighten the cable retainers.

11. If the convection box is not correctly aligned, release the tension on the cables by slackening the screws and turning the hexagonal adjusters fully anticlockwise. The convection box should then automatically realign itself. Pull each cable taut again and push the cable retainers back against the back panel. Again, tighten the screws in the retainers and apply tension to the cables by turning the hexagonal adjusters clockwise as far as possible.

12. Push the free length of the cables inside the convection box so that they are available to allow easy removal and refitting of the appliance during subsequent service calls.

9.3 Floor sealing.

Using the floor sealing tape supplied, seal the bottom of the convection box to the fireplace and hearth floor (See figure 16).

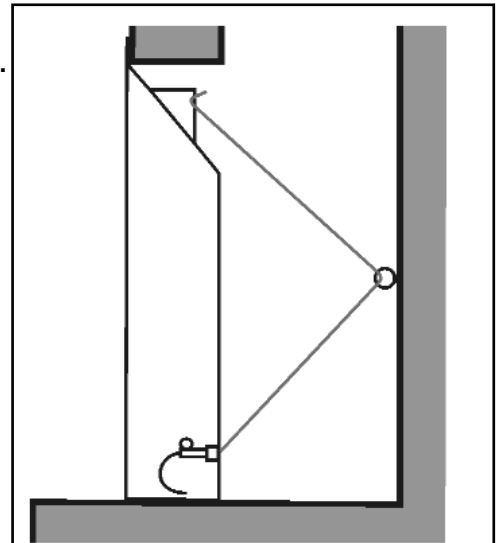

Figure 14. Cable route

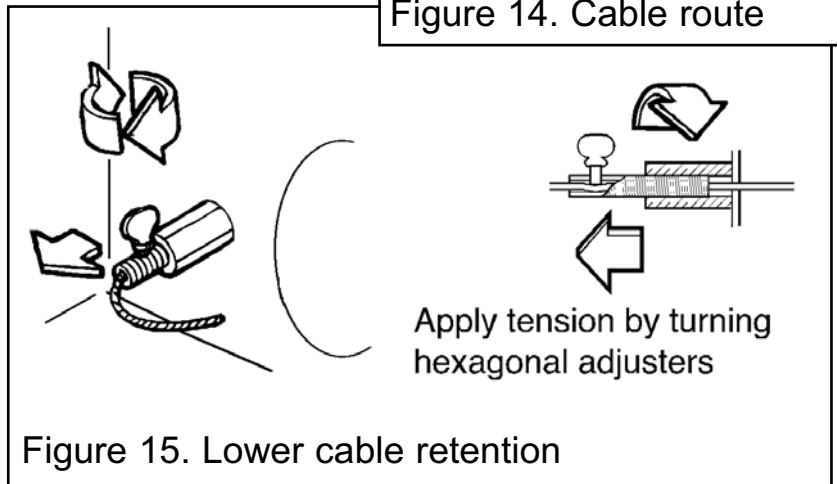

Figure 15. Lower cable retention

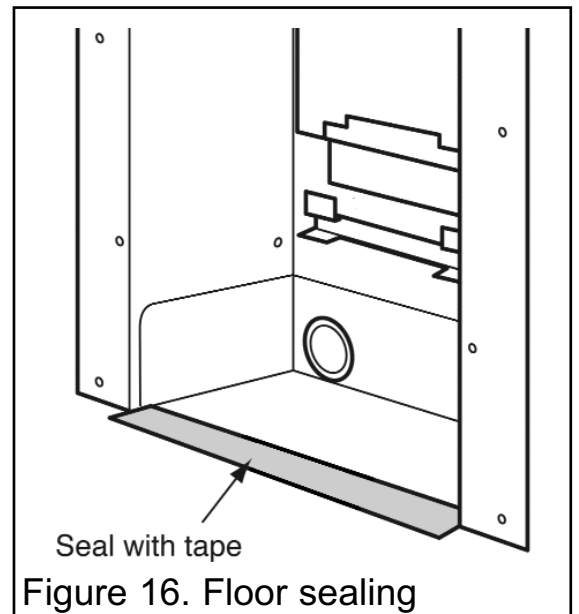

Figure 16. Floor sealing

10. BURNER INSTALLATION

10.1 Burner and supply pipe installation.

1. Refit the burner unit to the convection box with two screws.
2. Connect the supply line to the appliance.
3. Pressure check the installation pipework for gas soundness. In the United Kingdom check in accordance with the current edition of BS6891. In the Republic of Ireland refer to the current edition of I.S. 813 "Domestic gas installations".

10.2 Preliminary burner checks.

Some burner operations can be checked at this stage. Checking now will mean that less disassembly will be required if any problems are found. A full check should still be made, however, after final installation.

10.2.1 Lighting the burner.

1. Depress the control knob and slowly rotate it anticlockwise to the 'pilot ignition' position. A 'click' will be heard as the integral piezo operates. A spark should be seen between the electrode and pilot tip.
2. Turn the control knob clockwise to the 'OFF' position. Repeat this operation until a flame appears at the pilot. There may be a delay before the pilot lights due to air being purged from the system. When a flame appears at the pilot keep the control knob depressed and hold the pilot ignition position for ten seconds. When the control knob is released the pilot flame should remain lit.

10.2.2 Operating the burner.

1. When the pilot burner is operating properly, gradually turn the control knob anti-clockwise to 'HIGH' (Depress the knob slightly to get past the 'pilot ignition' position). The main burner should now light. Depress the control knob slightly to release from the 'HIGH' position and turn back (clockwise) to 'LOW'. While turning, the burner flames should gradually become lower but remain alight. Depress the control knob slightly to release from the 'LOW' position and turn back (clockwise) to the Pilot ignition position. The main burner should extinguish but the pilot should remain alight. Depress the control knob slightly and turn back (clockwise) to turn OFF. This will extinguish the pilot.

If the above checks are satisfactory, continue with the installation. If not, check the control and ignition circuitry and components.

INSTALLER GUIDE

10.3 Inlet pressure check.

The appliance is pre-set to give the correct heat input at the inlet pressure shown in section 2 of this manual. No adjustment is necessary.

1. Check the inlet pressure by fitting a pressure gauge at the test point. The test point is on the inlet 'T' connector (See figure 17). Check the pressure with the appliance alight and set at maximum output.
2. After checking, turn off the appliance. Remove the pressure gauge and replace the test point sealing screw.
3. Test around the sealing screw for gas soundness with a suitable leak detection fluid.

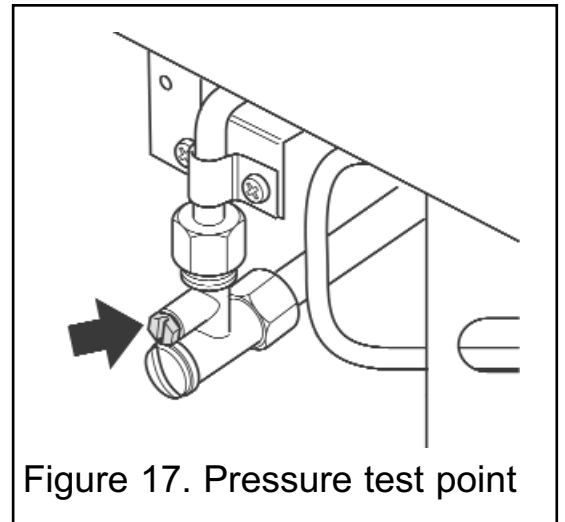

Figure 17. Pressure test point

10.4 Fitting the burner tray trim.

1. Fit the burner tray trim over the front rim of the burner tray. Push the trim fully down (See figure 18).

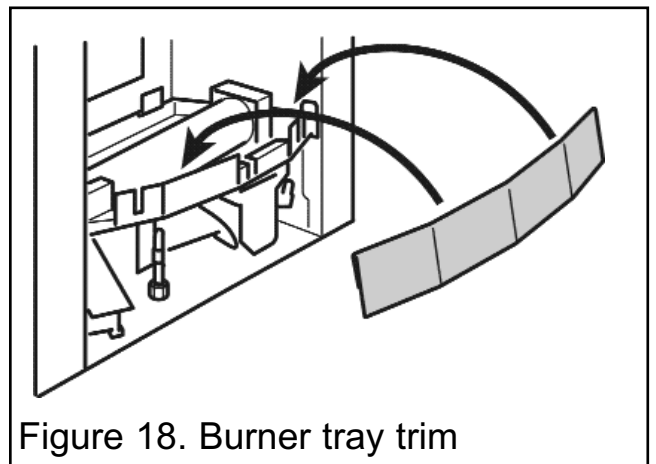

Figure 18. Burner tray trim

11. FITTING THE CERAMIC FUEL EFFECT

The installer and owner guide for the ceramic fuel effect is supplied with the ceramic fuel effect. It is important that the installer and owner guide for the ceramic fuel effect be placed inside or attached to this guide and handed to the customer following completion of the 'final review' section.

12. FITTING THE FASCIA

The fitting guide for the fascia is supplied with the fascia and the fascia should be fitted in accordance with it.

13. FULL OPERATING CHECKS

13.1 Check the control settings.

With the ceramic fuel effect in position the control operation must now be fully rechecked. Make sure that the isolating valve at the inlet elbow is open.

- *When first turned on from cold, the flames will appear predominantly blue.*
- *When operating the fire for the first time, some vapours may be given off which could set off smoke alarms in the vicinity. These vapours are quite normal with new appliances. They are totally harmless and will disappear after a few hours use.*

13.1.1 Lighting the burner.

1. If closed, open the isolating valve at the inlet elbow.
2. Depress the control knob and slowly rotate it anticlockwise to the pilot ignition position. A 'click' will be heard as the integral piezo operates. A spark should be seen between the electrode and pilot tip.
3. Turn the control knob clockwise to the 'OFF' position. Repeat this operation until a flame appears at the pilot. There may be a delay before the pilot lights due to air being purged from the system. When a flame appears at the pilot keep the control knob depressed and hold the pilot ignition position for five seconds. When the control knob is released the pilot flame should remain lit.

13.1.2 Operating the burner.

1. When the pilot burner is operating properly, gradually turn the control knob anti-clockwise to 'HIGH' (Depress the knob slightly to get past the pilot ignition position). The main burner should now light. Depress the control knob slightly to release from the 'HIGH' position and turn back (clockwise) to 'LOW'. While turning, the burner flames should gradually become lower but remain alight. Depress the control knob slightly to release from the 'LOW' position and turn back (clockwise) to the 'pilot ignition' position.

The main burner should extinguish but the pilot should remain alight. Depress the control knob slightly and turn back (clockwise) to turn off. This will extinguish the pilot.

If the above checks are satisfactory, continue with the installation. If not, check the control and ignition circuitry and components as described in the servicing section of this guide.

While cooling the ceramic fuel effect may make some crackling noises. This is quite normal.

INSTALLER GUIDE

14. SPILLAGE AND FLAME SUPERVISION CHECKS

14.1 Check for spillage.

A spillage check must be made before leaving the installed appliance with the customer. Make this with all the ceramic fuel effect pieces, fascia and firefront in position.

1. Close all doors and windows in the room containing the appliance.
2. Light the appliance and set the slide control to the maximum burning position.
3. Leave the appliance on for five minutes.
4. Place the smoke match into the appliance canopy (See figure 19).
5. The installation is satisfactory if the smoke is drawn into the appliance. If the smoke is not drawn into the appliance, leave the appliance alight at the maximum setting for a further ten minutes and then repeat the test. If smoke is still not drawn into the appliance, inspect the sealing to the fireplace surround. If the sealing is satisfactory but the appliance is installed with the flue restrictor (See section 8.3), remove the restrictor, reseal the appliance and retest. If smoke is still not drawn into the appliance, disconnect the appliance and seek expert advice.

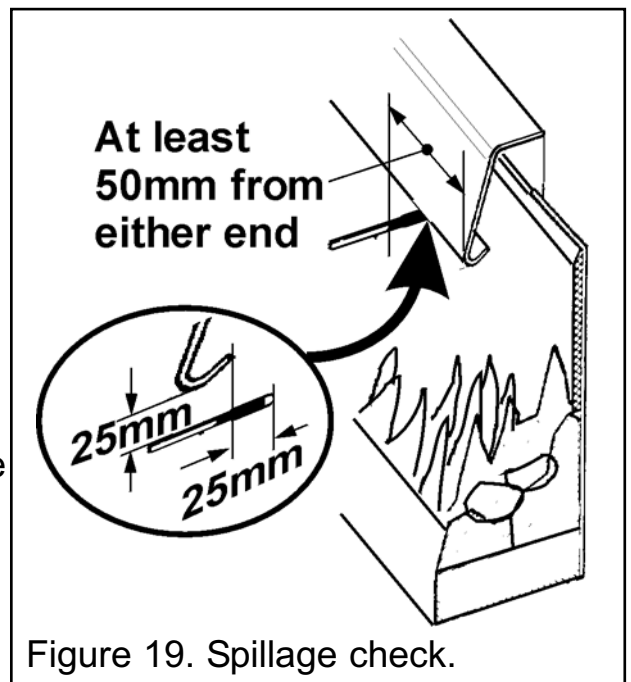

6. If the above test is satisfactory, open all internal connecting doors, hatches, etc., in the room. Keep all doors and windows that open to the outside of the building closed. Recheck for spillage as above. If an extractor fan is installed in the same room as the appliance or a connecting room, check that spillage does not occur with the fan operating and all doors and other openings between the fan and the appliance open. If the smoke is drawn into the appliance, continue with the installation. **If the test is not satisfactory, disconnect the appliance and advise the customer of the cause of failure.**

INSTALLER GUIDE

14.2 Flame supervision and spillage monitoring system.

This pilot unit includes a system that will automatically shut off the gas supply if the pilot flame goes out or if there is insufficient oxygen due to spillage or poor ventilation. Check that the system operates properly as follows;

1. Light the appliance. Set the slide control to the maximum burning position and leave for one minute.
2. Set the control to the Low burning position. Isolate the gas supply at the inlet 'T' connector. The pilot and main burner will go out. **Note the time when the pilot goes out.** Listen for a snap sound at the gas tap. **Note the time when the sound is heard.** This sound is caused by an electromagnetic valve shutting off the gas supply through the tap. The valve is located in the body of the tap. The valve should operate **within 60 seconds of the pilot going out.** If the valve does not operate within this time limit do not allow the appliance to be used until the fault has been corrected. **This monitoring system must not be adjusted, bypassed or put out of operation.**
This monitoring system, or any of its parts, must only be exchanged using authorised parts.
3. Open the isolating valve on the inlet 'T' connector. Screw on the end cap and test for leaks.
4. Set the slider to the "OFF" position.

INSTALLER GUIDE

15. FINAL REVIEW

1. Visually inspect the appliance. Clean off any marks incurred during installation.
2. Advise the customer how to operate the fire.
3. Explain to the customer that the appliance has a flame failure and spillage monitoring system. Point out the explanation of this system shown in the owner guide. Advise that if the fire goes out for any reason, wait at least three minutes before relighting. Stress that if the monitoring system repeatedly shuts off the fire, the appliance should be switched off and a specialist should be consulted. Point out that the lighting instruction details are on an information label attached at the bottom of the appliance.
4. Advise that the fire may give off a slight odour while new. This is quite normal and it will disappear after a short period of use.
5. Advise that any cleaning must only be carried out when the fire is off and cold.
6. Advise the customer that they should read the owner guide before operating the fire and always follow the advice in the section headed "Cleaning your fire".
7. Advise the customer that the appliance will operate to its maximum potential if the flue is primed during the first 20 – 30 minutes of use. To do this, simply set the control to its highest setting. This will also burn off any carbon deposits that may have formed during previous use.

If using the appliance for long periods it is beneficial to change between settings. This will also help to remove any carbon deposits that may form during use.

8. Recommend that the appliance should be serviced and the chimney inspected by a competent person at least annually.

If the appliance is in premises in the United Kingdom occupied by a tenant, point out that by law a landlord must have any gas appliance, flue and pipework which is situated in a tenant's premises checked for safety at least every 12 months.

9. Advise the customer that the castings, fascia, firebox and ceramic pieces can be cleaned as described in the owner guide and that the loose ceramic fuel effect pieces must be replaced as described in the installer and owner guide for the ceramic fuel effect.

Stress that no extra ceramic fuel effect pieces must be added over and above those supplied with the appliance and that any replacements must only be the authorised spares. Warn that ignoring this advice could cause incomplete clearance of the products of combustion with consequent health hazards.

10. Inform the customer that the Serial number for the appliance is located on an information label, located behind the firefront casting / firefront and underneath the burner.

11. Hand the literature pack with this guide to the customer.

INSTALLER GUIDE

16 SERVICING & PARTS REPLACEMENT

- **Always turn off the gas supply and allow to cool completely before commencing any servicing (The appliance inlet “T” connector incorporates an isolating valve).**
- **It is recommended that, at least once a year, the appliance is disconnected and the fireplace opening checked and cleared of any debris.**
- **This product uses fuel effect pieces and a burner compartment rear wall containing Refractory Ceramic Fibres (RCF), which are man-made vitreous silicate fibres. Excessive exposure to these materials may cause irritation to eyes, skin and respiratory tract. Consequently, it is important to take care when handling these articles to ensure that the release of dust is kept to a minimum. To ensure that the release of fibres from these RCF articles is kept to a minimum, during installation and servicing we recommend that you use a HEPA filtered vacuum to remove any dust and soot accumulated in and around the fire before and after working on the fire. When replacing these articles we recommend that the replaced items are not broken up, but are sealed within a heavy duty polythene bag, clearly labelled as RCF waste. RCF waste is classed as a stable, non-reactive hazardous waste and may be disposed at a landfill licenced to accept such waste. Protective clothing is not required when handling these articles, but we recommend the use of suitable gloves to prevent irritation. We also recommend you follow the normal hygiene rules of not smoking, eating or drinking in the work area and always wash your hands before eating or drinking.**
- **This appliance does not contain any component manufactured from asbestos or asbestos related products.**
- **Check that the appliance is clean and that soot or debris is not blocking the gaps between the ceramic fuel effect causing an imperfect flame.**
- **Check that soot or debris is not impairing the electrode spark or pilot burner.**
- **Check that soot or debris is not blocking any of the holes in the main burner.**
- **After servicing, make sure that the ceramic rear wall is replaced correctly as described in this guide and the ceramic fuel effect pieces are replaced correctly as described in the installer and owner guide supplied with the ceramic fuel effect. The ceramic fuel effect guide may have been placed inside or attached to this guide.**
- **Always test for gas soundness and spillage after servicing the appliance.**

INSTALLER GUIDE

16.1 Checking the aeration setting of the burner.

1. The aeration shutter is factory set and should not require adjustment. If the shutter is not as shown in figure 20 and requires adjustment, loosen the two aeration shutter screws, slide the aeration shutter to the position shown in figure 20 and tighten the fixing screws.

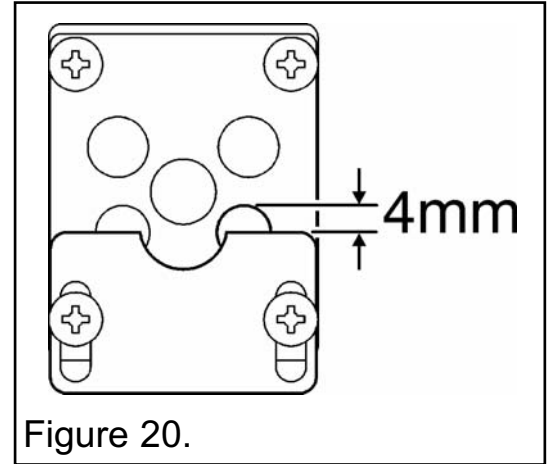

16.2 To remove the fascia.

Remove the fascia in the reverse order to that shown in the fascia installer and owner guide. The guide is supplied with the fascia and should be left inside or attached to this guide.

16.3 To remove the burner unit.

1. Remove the firefront casting and ash pan cover / firefront in the reverse order to that in section 16.2.

2. Remove the ceramic fuel effect. The ceramic fuel effect may cause staining / discolouration to decorative surfaces. It is therefore advisable to protect decorative surfaces.

3. Support the inlet elbow to avoid straining the pipework and disconnect the appliance from the inlet elbow.

4. Detach the burner unit from the convection box by removing two screws (See figure 21).

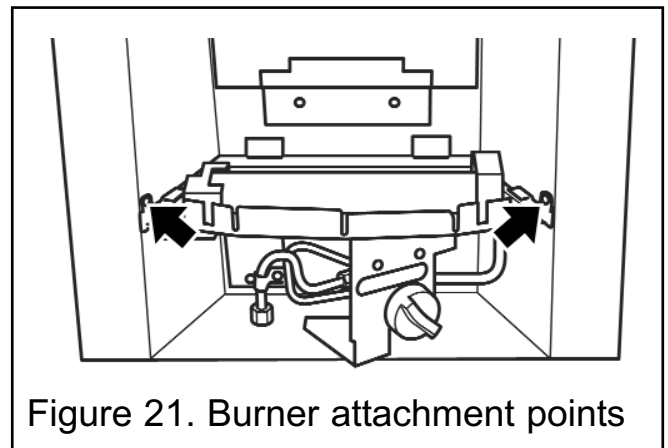

16.4 To remove the pilot unit.

1. Remove the burner unit (See section 16.3)

2. If lying the burner on its back, ensure that the work surface is suitably protected. This will avoid damage to the work surface.

3. Detach the pilot pipe from the pilot unit.

4. Detach the thermocouple from the gas valve.

5. Detach the electrode lead from the rear of the piezo spark generator on the gas valve.

6. Remove the two screws securing the pilot unit (See figure 22).

7. Refit in the reverse order.

Note: The pilot unit is an atmosphere sensing device. It must be replaced as a whole assembly. Its individual components are not separately replaceable.

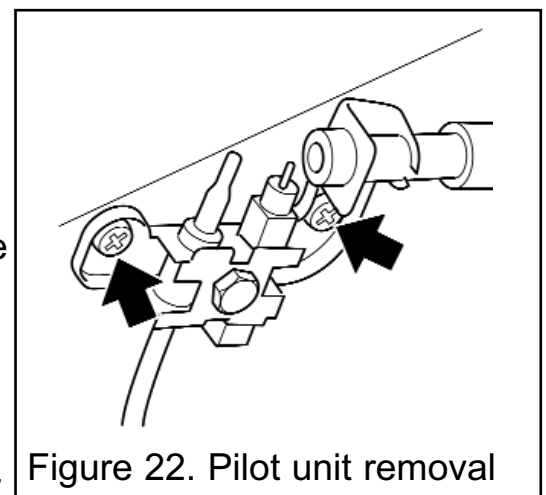

INSTALLER GUIDE

16.5 To remove the gas valve.

1. Remove the burner unit (See section 16.3).
2. If lying the burner on its back, ensure that the work surface is suitably protected. This will avoid damage to the work surface. Turn the burner unit upside down.
3. Detach the pilot pipe from the gas valve.
4. Detach the inlet pipe.
5. Detach the injector pipe.
6. Detach the electrode lead from the rear of the piezo spark generator on the gas valve.
7. Remove the control knob by pulling forward.
8. Remove the thermocouple by unscrewing the thermocouple nut at the gas valve.
9. Remove the hexagonal nut securing the gas valve to the mounting bracket.
10. Remove the gas valve.
11. Refit in the reverse order.

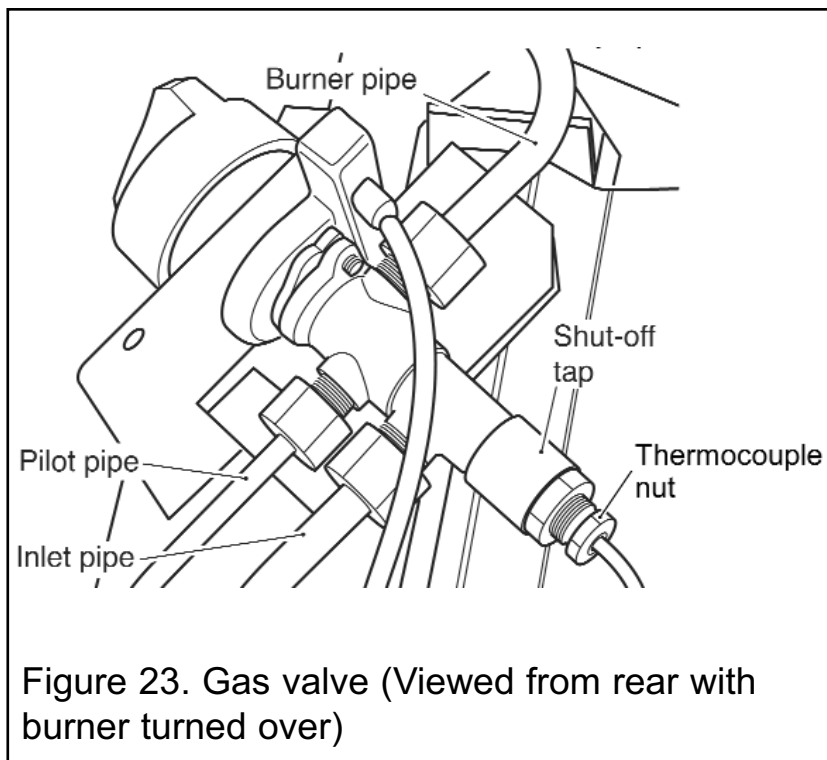

Figure 23. Gas valve (Viewed from rear with burner turned over)

16.6 To replace the burner.

1. Remove the burner unit (See section 16.3).
2. Support the elbow injector and unscrew the injector nut.
3. Remove the two screws from the burner clamping plate (See figure 24).
4. Lift the right hand side of the burner, slide it to the right and lift clear.
5. Refit in reverse order.

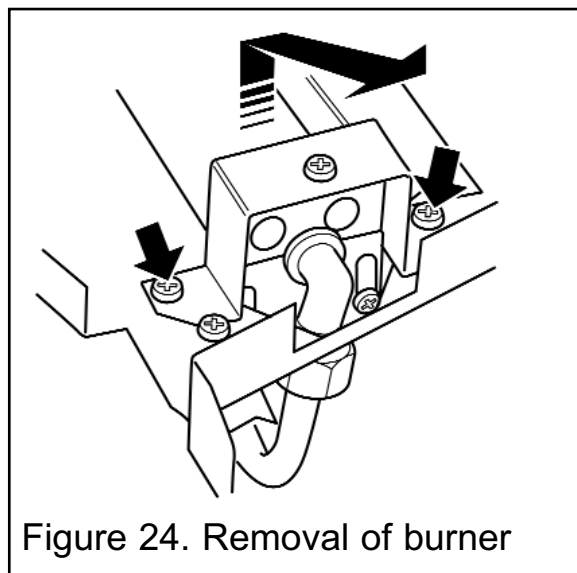

Figure 24. Removal of burner

INSTALLER GUIDE

16.7 To remove the main burner injector.

1. Remove the burner (See section 16.6).
2. Remove the burner clamping screw (See figure 25).
3. Unscrew the injector from the burner.
4. Refit in the reverse order.

16.8 To remove the appliance from the fireplace.

1. Remove the burner unit (See section 16.3).
2. If the fire retention is as method 1 (See section 9.1 of installation instructions), remove the fascia (See section 16.2) and then remove the fixing screws. If the fire retention is as method 2 (See section 9.2 of installation instructions), slacken the hexagonal adjusters on the cable retainers and unscrew the thumbscrews to release the cables.
3. Refit as described in the relevant installation sections. Make sure gas soundness, sealing, spillage test and performance are satisfactory.

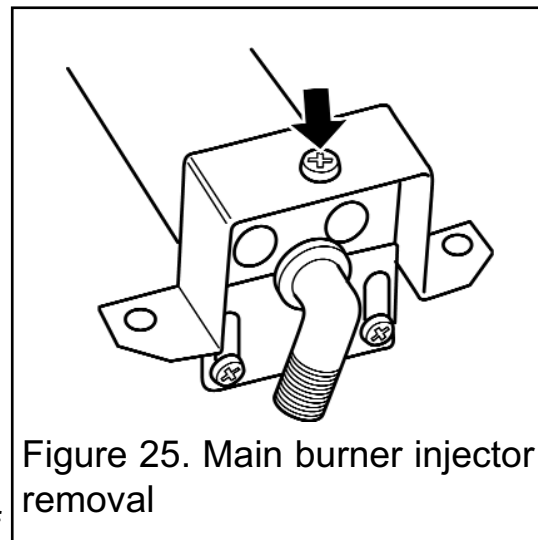

OWNER GUIDE

OWNER GUIDE

LIST OF CONTENTS

<u>Section</u>	<u>Page</u>
SAFETY	36
GAS CONSUMPTION	37
OPERATING YOUR FIRE	38
The Oxysafe flame sensing and flue blockage safety system.	38
Lighting the pilot.	38
Lighting the burner.	39
Selecting the heat setting.	39
Turning the fire back to pilot setting.	39
Turning the appliance off.	39
Lighting with a taper.	39
CLEANING YOUR FIRE	40
Metal parts.	40
Ceramic fuel effect and rear wall.	40
Burner.	40
CERAMIC FUEL BED REFITTING	41
MAINTENANCE	41
Regular maintenance.	41
Servicing.	41

This gas fire is designed to meet the most stringent quality, performance and safety requirements to provide you with many years' trouble-free service.

This guide aims to improve your understanding and appreciation of your gas fire by providing simple and informative instructions to ensure that you benefit from the excellent performance and features it has to offer.

IF YOU SMELL GAS

- **DON'T SMOKE.**
- **EXTINGUISH ALL NAKED FLAMES.**
- **DON'T TURN ELECTRICAL SWITCHES ON OR OFF.**
- **TURN OFF THE GAS SUPPLY AT THE METER OR TANK AS APPROPRIATE.**
- **OPEN DOORS AND WINDOWS TO GET RID OF THE GAS.**
- **IMMEDIATELY CALL THE GAS EMERGENCY SERVICE FROM A NEIGHBOURS PHONE - SEE YOUR LOCAL TELEPHONE DIRECTORY.**

Do have the fire installed by a competent person. In the United Kingdom, installation must be in accordance with the latest edition of the Gas Safety (installation & use) Regulations. In the Republic of Ireland, installation must be in accordance with all national and local regulations in force.

Do have the chimney swept prior to installation if it was previously used for solid fuel.

Do have the fire installed in accordance with the installation instructions.

Do provide a minimum clearance of 750mm from the top surface of the hearth to any shelf made of wood or other combustible material where the shelf is not more than 150mm deep. For a shelf deeper than 150mm, add 12.5mm to the clearance for every 25mm of additional shelf depth (See figure1).

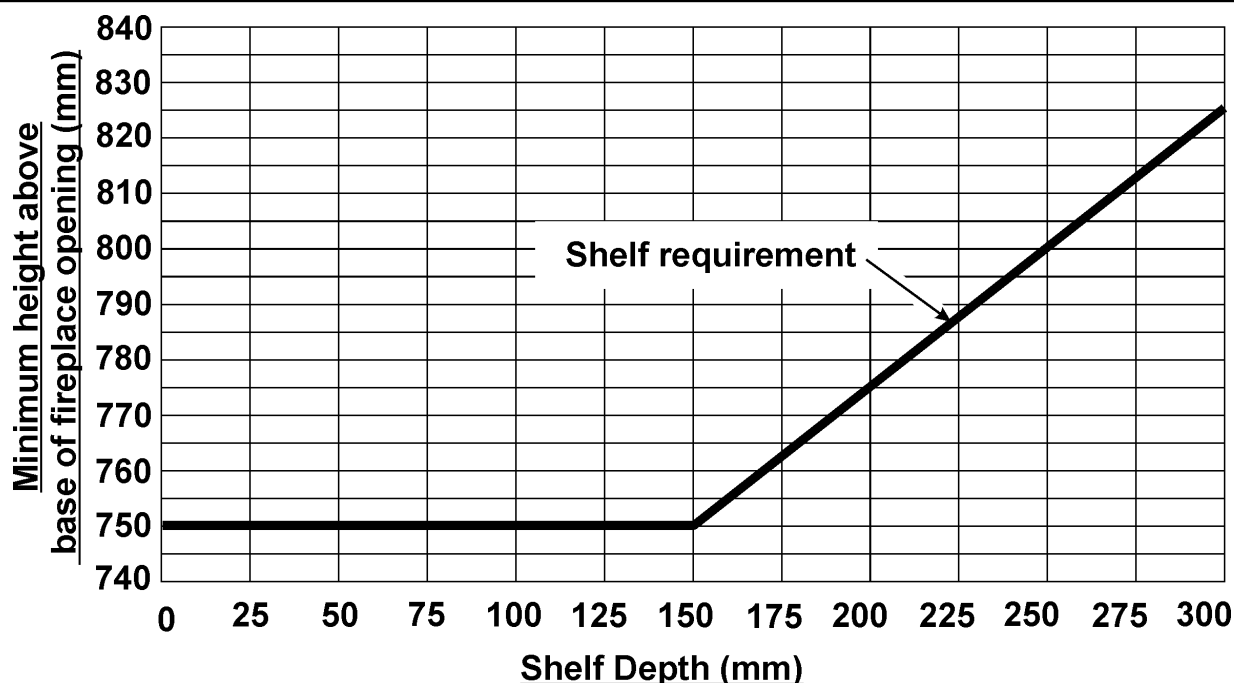

Figure 1. Combustible shelf clearances

Do always use a fireguard complying with BS 8423 for the protection of young children, the elderly or infirm.

Do wait three minutes before attempting to relight if the fire is switched off or the

OWNER GUIDE

flames are extinguished for any reason. (Your fire is fitted with a safety device that will automatically shut off the gas supply to the fire, if for any reason, the flame goes out)

Do get advice about the suitability of any wall covering near your fire. Soft wall coverings (e.g. embossed vinyl, etc.) which have a raised pattern are easily affected by heat. They may, therefore, scorch or become discoloured when close to a heating appliance. Please bear this in mind whenever you are considering redecorating.

Do provide a minimum side clearance as detailed below:

The minimum allowable distance from the outside of the fascia to a corner wall having combustible material or any other combustible surface which projects beyond the front of the appliance is 100mm.

For access purposes a 10mm clearance to non-combustible surfaces is recommended on the left side of the appliance, on the right side the recommended clearance is 50mm for access to the slider control.

Please bear this in mind if ever you are altering the room.

Don't hang clothing, towels or any other fabrics over the fire.

Don't put more ceramic fuel effect pieces on the fire than the number given in this guide or use any ceramic fuel effect pieces other than those authorised for this fire. Incorrect combustion could result.

Don't put paper or other materials onto your fire.

Don't use the fire with damaged base ceramics.

Don't place any combustible material (rugs, carpet, plastic tiles, etc.) on the hearth

Don't attempt to clean or service the fire until it has been switched off and allowed to cool completely.

GAS CONSUMPTION

Model 955

Has a maximum natural gas input of 6.0kW (Gross)

Has a maximum natural gas output of 3.3kW

Has a minimum natural gas input of 2.3kW (Gross)

Has a minimum natural gas output of 1.26kW

Model 955 when converted using kit number 0595221

Has a maximum propane gas input of 6.1kW (Gross)

Has a maximum propane gas output of 3.5kW

Has a minimum propane gas input of 3.8kW (Gross)

Has a minimum propane gas output of 2.2kW

OWNER GUIDE

OPERATING YOUR FIRE

PLEASE NOTE

When operating your fire for the first time, some vapours may be given off which may cause a slight odour and could possibly set off any smoke alarms in the immediate vicinity. These vapours are quite normal with new appliances. They are totally harmless and will disappear after a few hours use.

The Oxysafe flame sensing and flue blockage safety system.

For your safety, this appliance is fitted with a flue blockage safety device which will shut down the appliance in the event of abnormal flue conditions. **This device is NOT a substitute for an independently mounted Carbon Monoxide detector.**

The device will also automatically shut off the gas supply to the fire if the pilot flame goes out due to lack of oxygen or for any other reason.

If this device starts to repeatedly shut off the gas, get expert advice.

This device incorporates a probe which senses that the heat from the pilot flame is correct. If this probe is cool, the device will prevent any gas flow unless the control knob is kept depressed at the "Pilot/Ign" position.

If, for any reason, the flames go out when the fire is hot or if the fire is turned off when hot, **always wait at least three minutes before attempting to relight.**

Lighting the pilot.

This fire is controlled by a 4-position gas tap mounted on the front leg of the appliance. In addition to the "OFF" position there is a pilot light and 2 heat control settings (See figure 2).

- Depress the control knob and turn SLOWLY anticlockwise towards the "**Pilot/Ign**" position. A spark should be generated at the pilot while turning. The spark should ignite the pilot. The pilot flame can be seen through the lower left hand opening in the front of the fuel effect bed.
- Keep the button depressed at the "**Pilot/Ign**" position for a further ten seconds. This will prevent the flame-sensing device from shutting off the gas while its probe warms up.
- If the pilot does not ignite instantly, repeat procedure. **If after 10 seconds pilot ignition has not occurred, turn the control knob back to the "Off" position, wait for 3 minutes and then repeat the ignition procedure.**

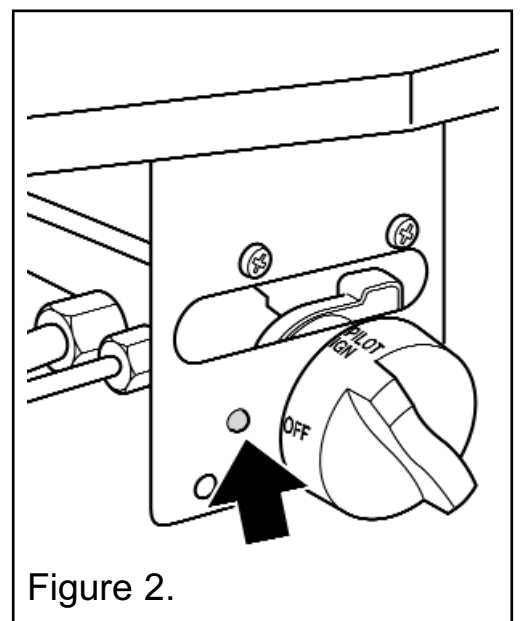

Figure 2.

OWNER GUIDE

Lighting the burner.

- Once the pilot light is established, the main burner can be lit by depressing and turning the control knob anticlockwise to the “**High**” position.

Selecting the heat setting.

- In order to change from one setting to another depress the control knob slightly and turn the knob to the required position. Any setting from “**Low**” to “**High**” may be selected.

Note: *The appliance will operate to its maximum potential if the flue is primed during the first 20-30 minutes of operation. To do this, simply operate the appliance at its “High” setting. This will also burn off any carbon deposits that may have formed during previous operations. If operating the appliance for long periods it is beneficial to change between settings. This will help to remove any carbon deposits that may form during operation.*

Turning the fire back to pilot setting.

- Depress the control knob and turn clockwise until the pilot setting is reached.

Turning the appliance off.

- Make sure that the control knob is in the pilot position. Depress the control knob and turn clockwise to the “**Off**” position.
- **Wait at least three minutes before relighting.**

Lighting with a taper.

(See figure 3).

In the unlikely event of failure of the ignition spark, the pilot can be lit by a taper or long spill. Insert the taper or spill through the lower left hand opening in the front of the fuel effect bed.

- Follow the section ‘Lighting the pilot’ as described previously.

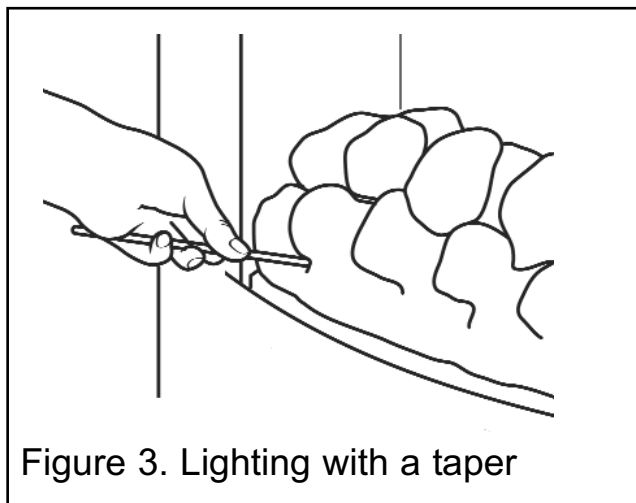

Figure 3. Lighting with a taper

To maintain the high performance and quality finish of your appliance, please follow these guidelines:

- Before attempting to clean the fire, please remember to turn off the fire and wait for the appliance to cool completely. The fire will retain heat for some time before cleaning can begin.
- If any pieces of debris are found in the firebox, have the chimney inspected before further use.

Metal parts.

- Clean the metal parts with a slightly damp, lint free non-abrasive cloth and then dry.
- Do **not** use abrasive cleaners, as these will scratch the fire surface.

Ceramic fuel effect and rear wall.

- **This product uses fuel effect pieces and burner compartment rear wall containing Refractory Ceramic Fibres (RCF), which are man-made vitreous silicate fibres. Excessive exposure to this material may cause irritation to eyes, skin and respiratory tract. Consequently, it is important to take care when handling these articles to ensure that the release of dust is kept to a minimum.**
- Light coatings of soot will usually be burnt off during the normal operation of the fire.
- Should any soot accumulation become excessive, the fuel effect pieces and walls should be removed from the fire for cleaning.
- Cleaning should be carried out in a well ventilated area or in the open air by gently brushing with the pieces held away from your face so that you avoid inhaling the dust.
- We suggest that you remove the ceramic fuel effect in the reverse order to that shown in the ceramic fuel effect installer and owner guide. This should have been left inside or attached to this guide by the installer.

Burner.

- The burner surface can be carefully cleaned to remove any loose particles after taking off the ceramic fuel effect. Make sure that no particles are pushed into the burner holes.

OWNER GUIDE

CERAMIC FUEL EFFECT REFITTING

The installer and owner guide for the ceramic fuel effect is separate from this guide. The installer may have attached it to this guide or placed it inside. It is important that the installer and owner guide for the ceramic fuel effect is followed correctly. If replacing the ceramic fuel effect, where a new guide is supplied, follow the installer and owner guide supplied with the replacement fuel effect. Keep the replacement installer and owner guide with this owner guide for future reference.

MAINTENANCE

Regular maintenance.

In order to achieve and maintain high levels of personal safety and performance efficiency, it is essential that the opening at the back of the fire and the flue are kept clear of any form of obstruction. It is possible that deposits of mortar or soot could fall and accumulate causing the flue to be blocked or restricted and so preventing proper clearance of dangerous exhaust fumes.

In the United Kingdom it is the law that a landlord must have any gas appliance, flue and pipework which is situated in a tenant's premises checked for safety at least every twelve months by a competent person (In the UK a GAS SAFE REGISTER engineer, Outside of the UK a CORGI or GAS SAFE REGISTER engineer).

We recommend that all gas appliances and their flues, wherever situated, are checked annually.

- When fitting replacement parts it is important that only approved parts are used for maximum safety.

Servicing.

IMPORTANT

To help us quickly help you, please try to have the following information available before you contact us:

Type of fire.

Model/Name.

Serial Number.

You will also be asked for the fault, problem or request plus your Post Code.

- If you wish to replace any of the ceramic fuel effect pieces, spare parts are available nationwide via the '**interpart** stockist network'. For your local stockist consult Yellow pages under Central Heating.
- **When fitting replacement parts it is important that only approved parts are used for maximum safety.**

